



**OWNER'S MANUAL**

***XJR1300***

***XJR1300***

**5EA-28199-E4**



Welcome to the Yamaha world of motorcycling!

As the owner of an XJR1300, you are benefiting from Yamaha's vast experience and newest technology regarding the design and manufacture of high-quality products, which have earned Yamaha a reputation for dependability.

Please take the time to read this manual thoroughly, so as to enjoy all advantages of your XJR1300. The owner's manual does not only instruct you in how to operate, inspect and maintain your motorcycle, but also in how to safeguard yourself and others from trouble and injury.

In addition, the many tips given in this manual will help keep your motorcycle in the best possible condition. If you have any further questions, do not hesitate to contact your Yamaha dealer.

The Yamaha team wishes you many safe and pleasant rides. So, remember to put safety first!

# IMPORTANT MANUAL INFORMATION

---

---

Particularly important information is distinguished in this manual by the following notations:



The Safety Alert Symbol means **ATTENTION! BECOME ALERT! YOUR SAFETY IS INVOLVED!**



Failure to follow **WARNING** instructions could result in severe injury or death to the motorcycle operator, a bystander, or a person inspecting or repairing the motorcycle.

**CAUTION:**

A **CAUTION** indicates special precautions that must be taken to avoid damage to the motorcycle.

**NOTE:**

A **NOTE** provides key information to make procedures easier or clearer.

**NOTE:**

- This manual should be considered a permanent part of this motorcycle and should remain with it even if the motorcycle is subsequently sold.
  - Yamaha continually seeks advancements in product design and quality. Therefore, while this manual contains the most current product information available at the time of printing, there may be minor discrepancies between your motorcycle and this manual. If you have any questions concerning this manual, please consult your Yamaha dealer.
-

# IMPORTANT MANUAL INFORMATION

---

---

EW000002

 **WARNING**

**PLEASE READ THIS MANUAL CAREFULLY AND COMPLETELY BEFORE OPERATING THIS MOTORCYCLE.**

---

# **IMPORTANT MANUAL INFORMATION**

---

---

EAU04229

**XJR1300  
OWNER'S MANUAL  
©2001 by Yamaha Motor Co., Ltd.  
1st edition, July 2001  
All rights reserved.  
Any reprinting or unauthorized use  
without the written permission of  
Yamaha Motor Co., Ltd.  
is expressly prohibited.  
Printed in Japan.**

1 GIVE SAFETY THE RIGHT OF WAY	1
2 DESCRIPTION	2
3 INSTRUMENT AND CONTROL FUNCTIONS	3
4 PRE-OPERATION CHECKS	4
5 OPERATION AND IMPORTANT RIDING POINTS	5
6 PERIODIC MAINTENANCE AND MINOR REPAIR	6
7 MOTORCYCLE CARE AND STORAGE	7
8 SPECIFICATIONS	8
9 CONSUMER INFORMATION	9
INDEX	







# GIVE SAFETY THE RIGHT OF WAY

---

---

GIVE SAFETY THE RIGHT OF WAY ..... 1-1



Motorcycles are fascinating vehicles, which can give you an unsurpassed feeling of power and freedom. However, they also impose certain limits, which you must accept; even the best motorcycle does not ignore the laws of physics.

Regular care and maintenance are essential for preserving value and operating condition of your motorcycle. Moreover, what is true for the motorcycle is also true for the rider: good performance depends on being in good shape. Riding under the influence of medication, drugs and alcohol is, of course, out of the question. Motorcycle riders—more than car drivers—must always be at their mental and physical best. Under the influence of even small amounts of alcohol, there is a tendency to take dangerous risks.

Protective clothing is as essential for the motorcycle rider as seat belts are for car drivers and passengers. Always wear a complete motorcycle suit (whether made of leather or tear-resistant synthetic materials with protectors), sturdy boots, motorcycle gloves and a properly fitting helmet. Optimum protective wear, however, should not encourage carelessness. Although full-coverage helmets and suits, in particular, create an illusion of total safety and protection, motorcyclists will always be vulnerable. Riders who lack critical self-control run the risk of going too fast and are apt to take chances. This is even more dangerous in wet weather. The good motorcyclist rides safely, predictably and defensively—avoiding all dangers, including those caused by others.

Enjoy your ride!

Left view .....	2-1
Right view.....	2-2
Controls and instruments .....	2-3

## Left view

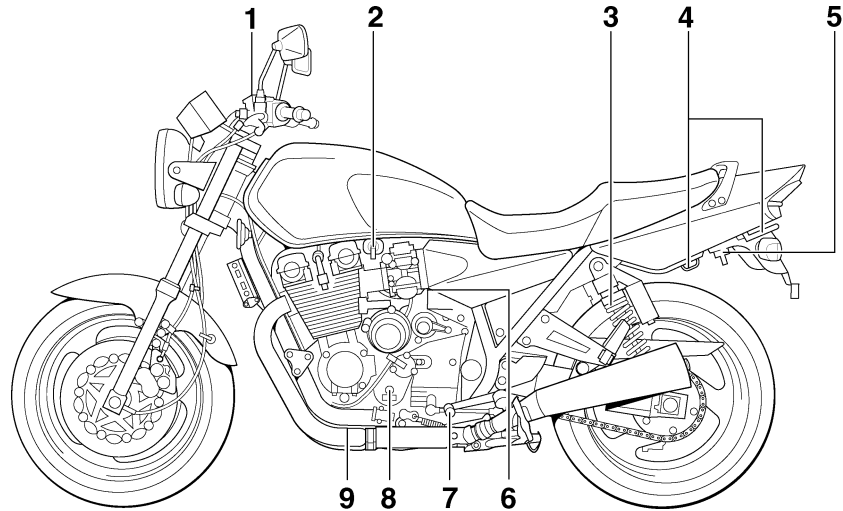

- |   |                       |
|---|-----------------------|
| 1. Clutch fluid reservoir                                 | (page 6-20)           |
| 2. Fuel cock  | (page 3-10)           |
| 3. Shock absorber assembly spring preload adjusting rings | (page 3-15)           |
| 4. Luggage strap holders                                  | (page 3-16)           |
| 5. Helmet holder/seat lock                                | (page 3-12/page 3-11) |
| 6. Throttle stop screw                                    | (page 6-13)           |
| 7. Shift pedal  | (page 3-6)            |
| 8. Engine oil filler element                              | (page 6-8)            |
| 9. Engine oil drain bolt                                  | (page 6-8)            |

## Right view

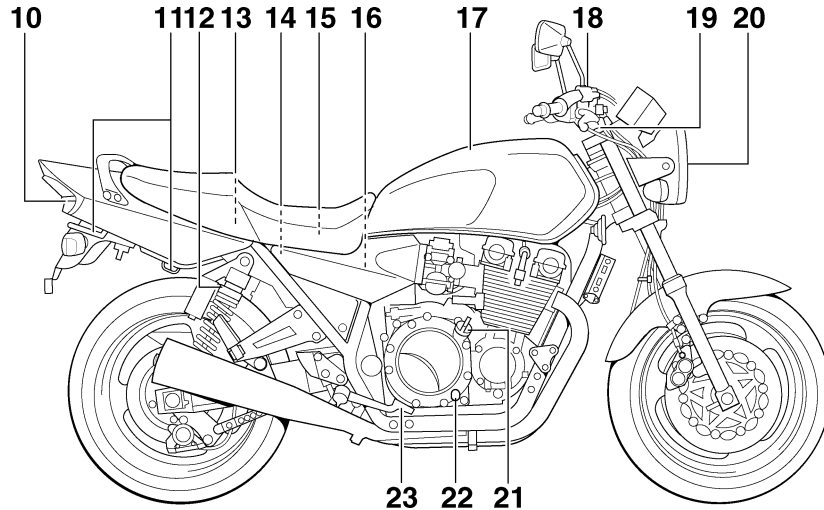

10. Tail/brake light	(page 6-31)	16. Air filter element	(page 6-11)
11. Luggage strap holders	(page 3-16)	17. Fuel tank	(page 3-8)
12. Shock absorber assembly spring preload adjusting rings	(page 3-15)	18. Front brake fluid reservoir	(page 6-19)
13. Owner's tool kit	(page 6-1)	19. Front fork spring preload adjusting bolt	(page 3-14)
14. Rear brake fluid reservoir	(page 6-19)	20. Headlight	(page 6-29)
15. Fuses	(page 6-29)	21. Engine oil filler cap	(page 6-8)
		22. Engine oil level check window	(page 6-8)
		23. Brake pedal	(page 3-7)

# DESCRIPTION

## Controls and instruments

2

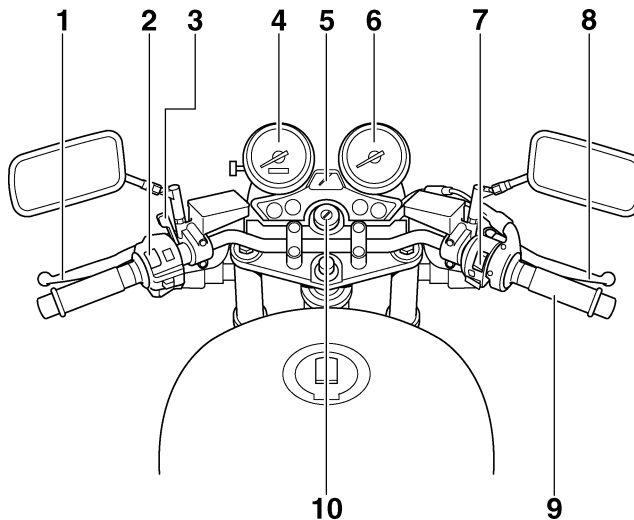

- 1. Clutch lever
- 2. Left handlebar switches
- 3. Starter (choke) lever
- 4. Speedometer unit
- 5. Fuel gauge
- 6. Tachometer

- (page 3-5)
- (page 3-4)
- (page 3-11)
- (page 3-3)
- (page 3-3)
- (page 3-3)

- 7. Right handlebar switches
- 8. Brake lever
- 9. Throttle grip
- 10. Main switch/steering lock

- (page 3-5)
- (page 3-7)
- (page 6-13)
- (page 3-1)

# INSTRUMENT AND CONTROL FUNCTIONS

Main switch/steering lock .....	3-1	Fuel tank breather hose .....	3-10
Indicator and warning lights .....	3-2	Fuel cock .....	3-10
Speedometer unit .....	3-3	Starter (choke) lever .....	3-11
Tachometer .....	3-3	Seat .....	3-11
Fuel gauge .....	3-3	Helmet holder .....	3-12
Anti-theft alarm (optional) .....	3-4	Storage compartment .....	3-13
Handlebar switches .....	3-4	Adjusting the front fork .....	3-13
Clutch lever .....	3-5	Adjusting the shock absorber assemblies .....	3-15
Shift pedal .....	3-6	Luggage strap holders .....	3-16
Brake lever .....	3-7	Sidestand .....	3-17
Brake pedal .....	3-7	Ignition circuit cut-off system .....	3-17
Fuel tank cap .....	3-8		
Fuel .....	3-9		

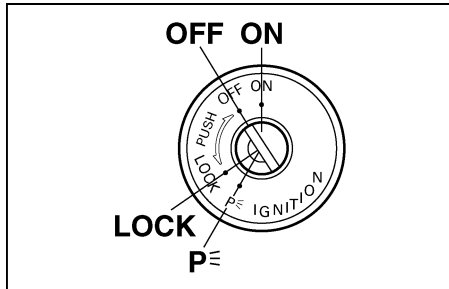

EAU00029

## Main switch/steering lock

The main switch/steering lock controls the ignition and lighting systems, and is used to lock the steering. The various positions are described below.

### ON

EAU00036

All electrical systems are supplied with power, and the engine can be started. The key cannot be removed.

### OFF

EAU00038

All electrical systems are off. The key can be removed.

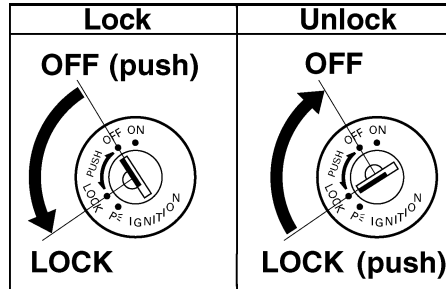

EAU00041

## LOCK

The steering is locked, and all electrical systems are off. The key can be removed.

### To lock the steering

1. Turn the handlebars all the way to the left or right.
2. Push the key in from the "OFF" position, and then turn it to "LOCK" while still pushing it.
3. Remove the key.

### To unlock the steering

Push the key into the main switch, and then turn it to "OFF" while still pushing it.

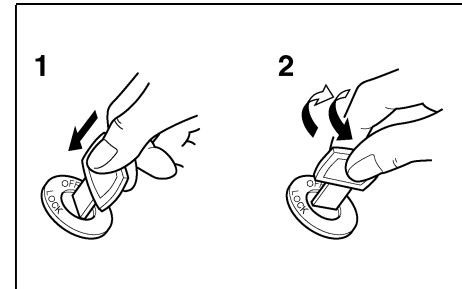

1. Push.
2. Turn.

EW000016

## ! WARNING

Never turn the key to "OFF" or "LOCK" while the motorcycle is moving, otherwise the electrical systems will be switched off, which may result in loss of control or an accident. Make sure that the motorcycle is stopped before turning the key to "OFF" or "LOCK".



# INSTRUMENT AND CONTROL FUNCTIONS

## P≡ (Parking)

EAU04356

The steering is locked, the taillight and auxiliary light are on, and the hazard light can be turned on, but all other electrical systems are off. The key can be removed.





The steering must be locked before the key can be turned to “P≡”.

ECA00043

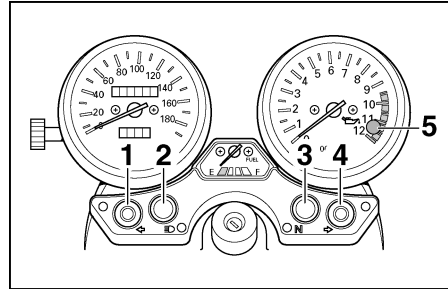
### CAUTION:

**Do not use the parking position for an extended length of time, otherwise the battery may discharge.**



1. Left turn signal indicator light “”
2. High beam indicator light “”
3. Neutral indicator light “N”
4. Right turn signal indicator light “”
5. Oil level warning light “”

EAU03034

## Indicator and warning lights

### Turn signal indicator lights “” and “”

EAU04121

The corresponding indicator light flashes when the turn signal switch is pushed to the left or right.

### High beam indicator light “”

EAU00063

This indicator light comes on when the high beam of the headlight is switched on.

### Neutral indicator light “N”

EAU00061

This indicator light comes on when the transmission is in the neutral position.

### Oil level warning light “”

EAU03201

This warning light comes on when the engine oil level is low.

The electrical circuit of the warning light can be checked according to the following procedure.

1. Set the engine stop switch to “” and turn the key to “ON”.
2. Shift the transmission into the neutral position or pull the clutch lever.
3. Push the start switch. If the warning light does not come on while pushing the start switch, have a Yamaha dealer check the electrical circuit.

### NOTE:

Even if the oil level is sufficient, the warning light may flicker when riding on a slope or during sudden acceleration or deceleration, but this is not a malfunction.

# INSTRUMENT AND CONTROL FUNCTIONS

3

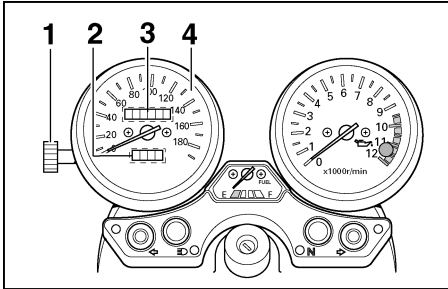

1. Tripmeter reset knob
2. Tripmeter
3. Odometer
4. Speedometer

EAU00097

## Speedometer unit

The speedometer unit is equipped with a speedometer, an odometer and a tripmeter. The speedometer shows riding speed. The odometer shows the total distance traveled. The tripmeter shows the distance traveled since it was last set to zero with the reset knob. The tripmeter can be used together with the fuel gauge to estimate the distance that can be traveled with a full tank of fuel. This information will enable you to plan future fuel stops.

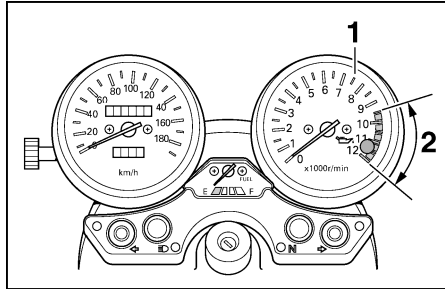

1. Tachometer
2. Tachometer red zone

EAU00101

## Tachometer

The electric tachometer allows the rider to monitor the engine speed and keep it within the ideal power range.

EC000003

### CAUTION:

**Do not operate the engine in the tachometer red zone.**

**Red zone: 9,500 r/min and above**

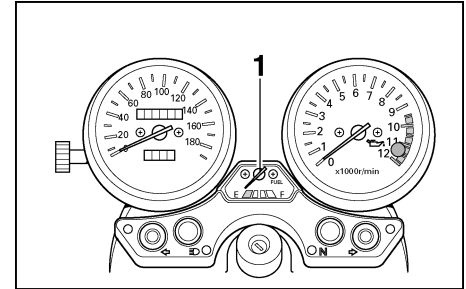

1. Fuel gauge

EAU00110

## Fuel gauge

The fuel gauge indicates the amount of fuel in the fuel tank. The needle moves towards “E” (Empty) as the fuel level decreases. When the needle reaches “E”, approximately 4.5 L of fuel remain in the fuel tank. If this occurs, refuel as soon as possible.

### NOTE:

Do not allow the fuel tank to empty itself completely.

# INSTRUMENT AND CONTROL FUNCTIONS

## Anti-theft alarm (optional)

EAU00109

This motorcycle can be equipped with an optional anti-theft alarm by a Yamaha dealer. Contact a Yamaha dealer for more information.

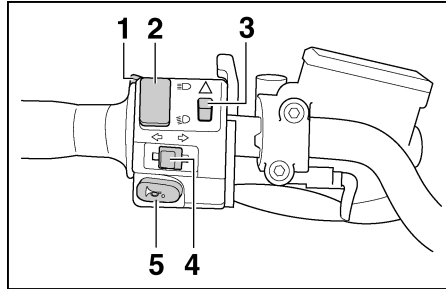

1. Pass switch “PASS”
2. Dimmer switch “ $\equiv\bigcirc/\equiv\bigcirc$ ”
3. Hazard switch “ $\triangle$ ”
4. Turn signal switch “ $\leftarrow/\rightarrow$ ”
5. Horn switch “ $\text{📢}$ ”

## Handlebar switches

EAU00118

### Pass switch “PASS”

EAU00120

Press this switch to flash the headlight.

### Dimmer switch “ $\equiv\bigcirc/\equiv\bigcirc$ ”

EAU03888

Set this switch to “ $\equiv\bigcirc$ ” for the high beam and to “ $\equiv\bigcirc$ ” for the low beam.

### Hazard switch “ $\triangle$ ”

EAU03826

With the key in the “ON” or “ $\rho\leq$ ” position, use this switch to turn on the hazard light (simultaneous flashing of all turn signal lights).

The hazard light is used in case of an emergency or to warn other drivers when your motorcycle is stopped where it might be a traffic hazard.

### CAUTION:

**Do not use the hazard light for an extended length of time, otherwise the battery may discharge.**

EC000006

### Turn signal switch “ $\leftarrow/\rightarrow$ ”

EAU03889

To signal a right-hand turn, push this switch to “ $\rightarrow$ ”. To signal a left-hand turn, push this switch to “ $\leftarrow$ ”. When released, the switch returns to the center position. To cancel the turn signal lights, push the switch in after it has returned to the center position.

### Horn switch “ $\text{📢}$ ”

EAU00129

Press this switch to sound the horn.

# INSTRUMENT AND CONTROL FUNCTIONS

3

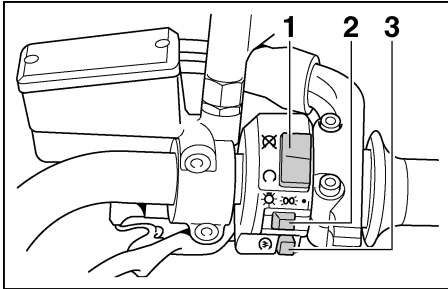

1. Engine stop switch “”
2. Light switch “ / / ”
3. Start switch “”

EAU03890

## Engine stop switch “”

Set this switch to “” before starting the engine. Set this switch to “” to stop the engine in case of an emergency, such as when the motorcycle overturns or when the throttle cable is stuck.

EAU03898

## Light switch “ / / ”

Set this switch to “ ” to turn on the auxiliary light, meter lighting and tail-light. Set the switch to “” to turn on the headlight also. Set the switch to “” to turn off all the lights.

EAU00143

## Start switch “”

Push this switch to crank the engine with the starter.

EC000005

### CAUTION:

**See page 5-1 for starting instructions prior to starting the engine.**

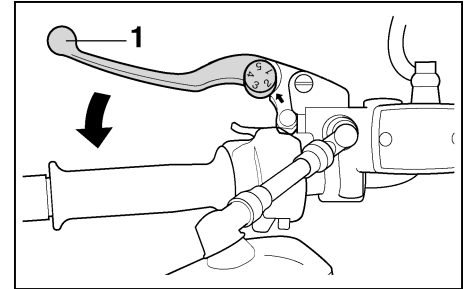

1. Clutch lever

EAU00153

## Clutch lever

The clutch lever is located at the left handlebar grip. To disengage the clutch, pull the lever toward the handlebar grip. To engage the clutch, release the lever. The lever should be pulled rapidly and released slowly for smooth clutch operation.

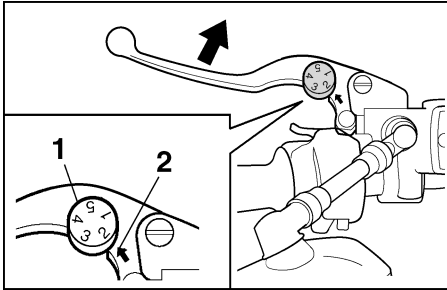

1. Clutch lever position adjusting dial
2. Arrow mark

The clutch lever is equipped with a clutch lever position adjusting dial. To adjust the distance between the clutch lever and the handlebar grip, turn the adjusting dial while holding the lever pushed away from the handlebar grip. Make sure that the appropriate setting on the adjusting dial is aligned with the arrow mark on the clutch lever.

The clutch lever is equipped with a clutch switch, which is part of the ignition circuit cut-off system. (See page 3-17 for an explanation of the ignition circuit cut-off system.)

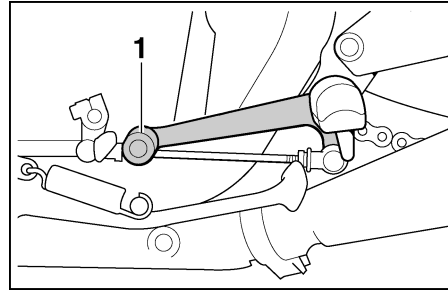

1. Shift pedal

EAU00157

## Shift pedal

The shift pedal is located on the left side of the engine and is used in combination with the clutch lever when shifting the gears of the 5-speed constant-mesh transmission equipped on this motorcycle.

# INSTRUMENT AND CONTROL FUNCTIONS

3

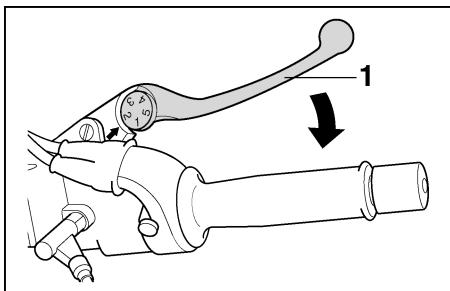

1. Brake lever

EAU00161

## Brake lever

The brake lever is located at the right handlebar grip. To apply the front brake, pull the lever toward the handlebar grip.

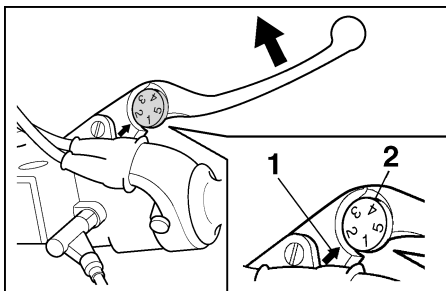

1. Arrow mark
2. Brake lever position adjusting dial

The brake lever is equipped with a position adjusting dial. To adjust the distance between the brake lever and the handlebar grip, turn the adjusting dial while holding the lever pushed away from the handlebar grip. Make sure that the appropriate setting on the adjusting dial is aligned with the arrow mark on the brake lever.

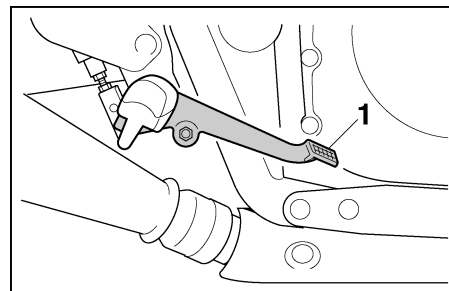

1. Brake pedal

EAU00162

## Brake pedal

The brake pedal is on the right side of the motorcycle. To apply the rear brake, press down on the brake pedal.

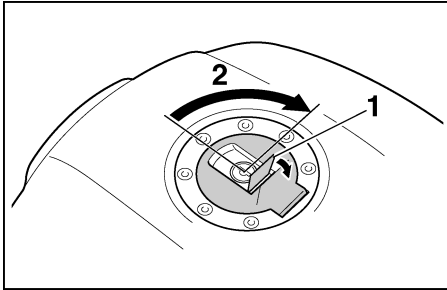

1. Fuel tank cap lock cover
2. Unlock.

EAU02935

## Fuel tank cap

### To open the fuel tank cap

Open the fuel tank cap lock cover, insert the key into the lock, and then turn it 1/4 turn clockwise. The lock will be released and the fuel tank cap can be opened.

### To close the fuel tank cap

1. Push the fuel tank cap into position with the key inserted in the lock.

2. Turn the key counterclockwise to the original position, remove it, and then close the lock cover.

### NOTE: \_\_\_\_\_

The fuel tank cap cannot be closed unless the key is in the lock. In addition, the key cannot be removed if the cap is not properly closed and locked.

EWA00025

### **WARNING**

**Make sure that the fuel tank cap is properly closed before riding.**

# INSTRUMENT AND CONTROL FUNCTIONS

3

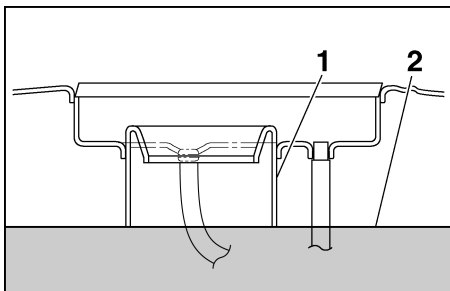

1. Fuel tank filler tube
2. Fuel level

EAU03753

## Fuel

Make sure that there is sufficient fuel in the tank. Fill the fuel tank to the bottom of the filler tube as shown.

EW000130

### **!** WARNING

- Do not overfill the fuel tank, otherwise it may overflow when the fuel warms up and expands.
- Avoid spilling fuel on the hot engine.

EAU00185

**CAUTION:** Immediately wipe off spilled fuel with a clean, dry, soft cloth, since fuel may deteriorate painted surfaces or plastic parts.

EAU04284

Recommended fuel:  
REGULAR UNLEADED  
GASOLINE ONLY

Fuel tank capacity:

Total amount:

21 L

Reserve amount:

4.5 L

ECA00104

**CAUTION:** Use only unleaded gasoline. The use of leaded gasoline will cause severe damage to internal engine parts, such as the valves and piston rings, as well as to the exhaust system.

Your Yamaha engine has been designed to use regular unleaded gasoline with a research octane number of 91 or higher. If knocking (or pinging) occurs, use a gasoline of a different brand or premium unleaded fuel. Use of unleaded fuel will extend spark plug life and reduce maintenance costs.



# INSTRUMENT AND CONTROL FUNCTIONS

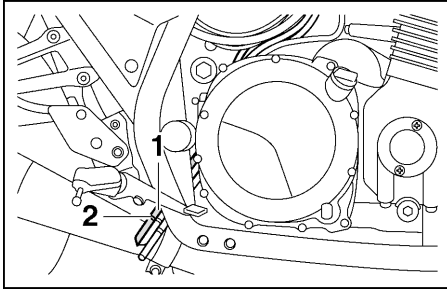

1. Fuel tank breather hose
2. Original position (white mark)

EAU02955

## Fuel tank breather hose

Before operating the motorcycle:

- Check the fuel tank breather hose connection.
- Check the fuel tank breather hose for cracks or damage, and replace it if damaged.
- Make sure that the end of the fuel tank breather hose is not blocked, and clean it if necessary.

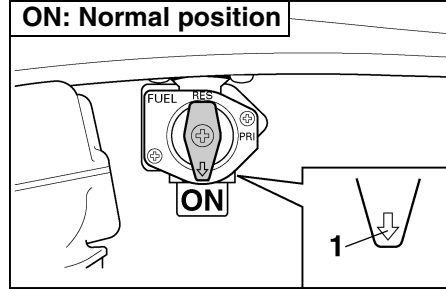

1. Arrow mark positioned over "ON"

EAU00207

## Fuel cock

The fuel cock supplies fuel from the tank to the carburetors while also filtering it.

The fuel cock lever positions are explained as follows and shown in the illustrations.

### ON

With the fuel cock lever in this position, fuel flows to the carburetors when the engine is running. Turn the fuel cock lever to this position when starting the engine and riding.

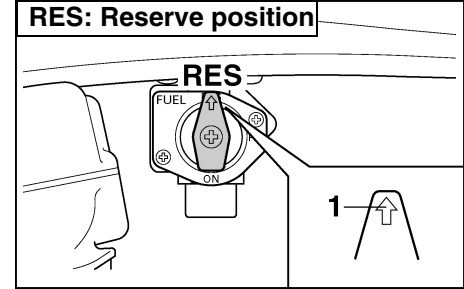

1. Arrow mark positioned over "RES"

### RES

This indicates reserve. With the fuel cock lever in this position, the fuel reserve is made available. Quickly turn the fuel cock lever to this position if you run out of fuel while riding, otherwise the engine may stall and will have to be primed (see "PRI"). After turning the fuel cock lever to "RES", refuel as soon as possible and be sure to turn the fuel cock lever back to "ON"!

# INSTRUMENT AND CONTROL FUNCTIONS

## PRI: Priming position

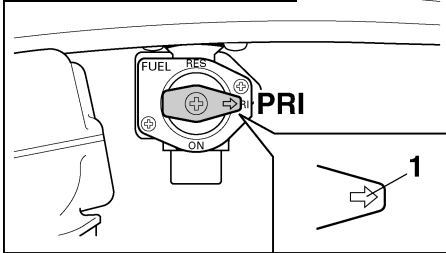

1. Arrow mark positioned over "PRI"

## PRI

This indicates prime. With the fuel cock lever in this position, the engine can be "primed". Turn the fuel cock lever to this position when the engine has been allowed to run out of fuel. This sends fuel directly to the carburetors, which will make starting easier. After the engine has started, be sure to turn the lever to "ON" (or "RES" if you have not refueled yet).

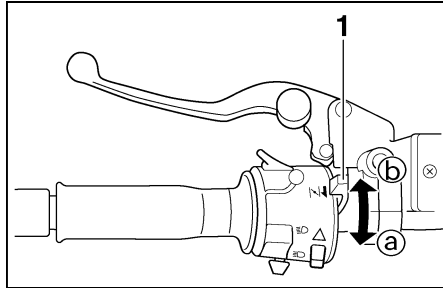

1. Starter (choke) lever " | \ | "

## Starter (choke) lever " | \ | "

EAU03839

Starting a cold engine requires a richer air-fuel mixture, which is supplied by the starter (choke). Move the lever in direction **a** to turn on the starter (choke). Move the lever in direction **b** to turn off the starter (choke).

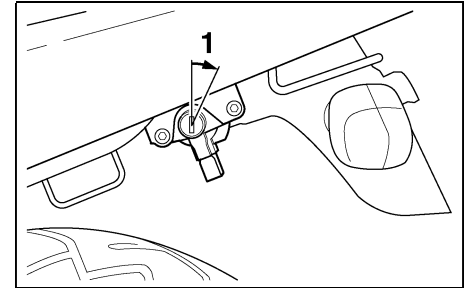

1. Unlock.

## Seat

EAU04406

### To remove the seat

1. Insert the key into the seat lock, and then turn it as shown.
2. Pull the seat off.

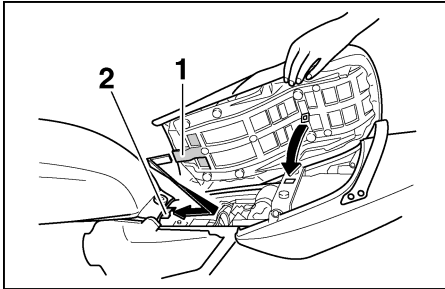

1. Projection
2. Seat holder

## To install the seat

1. Insert the projection on the front of the seat into the seat holder as shown.
2. Push the rear of the seat down to lock it in place.
3. Remove the key.

**NOTE:** \_\_\_\_\_  
Make sure that the seat is properly secured before riding.  
\_\_\_\_\_

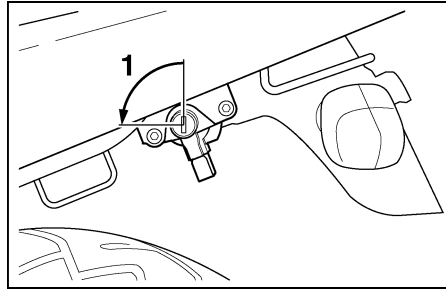

1. Unlock.

EAU04291

## Helmet holder

To open the helmet holder, insert the key into the seat lock, and then turn the key as shown.

To lock the helmet holder, turn the key to the original position, and then remove it.

EW000030

## **!** WARNING

**Never ride with a helmet attached to the helmet holder, since the helmet may hit objects, causing loss of control and possibly an accident.**

# INSTRUMENT AND CONTROL FUNCTIONS

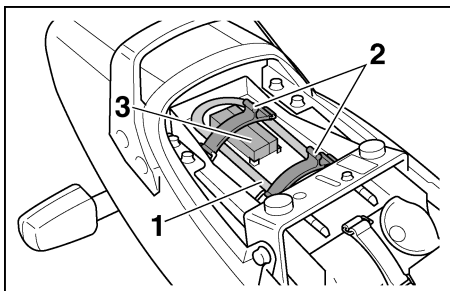

1. U-LOCK bar
2. Strap (× 2)
3. Lock of the U-LOCK

EAU04292

## Storage compartment

This storage compartment is designed to hold an optional genuine Yamaha U-LOCK. (Other locks may not fit.) When placing a U-LOCK in the storage compartment, securely fasten it with the straps. When the U-LOCK is not in the storage compartment, be sure to secure the straps to prevent losing them.

When storing the owner's manual or other documents in the storage compartment, be sure to wrap them in a plastic bag so that they will not get wet. When washing the motorcycle, be careful not to let any water enter the storage compartment.

EAU00285

## Adjusting the front fork

This front fork is equipped with spring preload adjusting bolts.

EW000035

### **! WARNING**

**Always adjust both fork legs equally, otherwise poor handling and loss of stability may result.**

# INSTRUMENT AND CONTROL FUNCTIONS

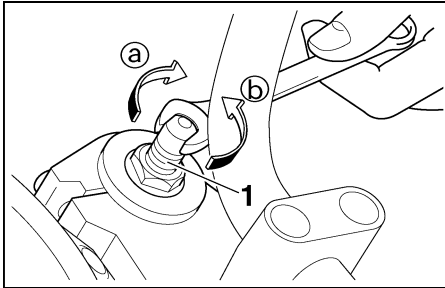

1. Spring preload adjusting bolt

Adjust the spring preload as follows.

To increase the spring preload and thereby harden the suspension, turn the adjusting bolt on each fork leg in direction (a). To decrease the spring preload and thereby soften the suspension, turn the adjusting bolt on each fork leg in direction (b).

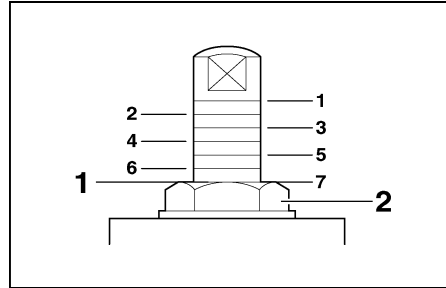

1. Current setting  
2. Front fork cap bolt

**NOTE:** \_\_\_\_\_  
Align the appropriate groove on the adjusting mechanism with the top of the front fork cap bolt.

	Setting
Minimum (soft)	7
Standard	5
Maximum (hard)	1

# INSTRUMENT AND CONTROL FUNCTIONS

## Adjusting the shock absorber assemblies

EAU04407

Each shock absorber assembly is equipped with a spring preload adjusting ring.

EC000015

### CAUTION:

Never attempt to turn an adjusting mechanism beyond the maximum or minimum settings.

EW000040

### ! WARNING

Always adjust both shock absorber assemblies equally, otherwise poor handling and loss of stability may result.

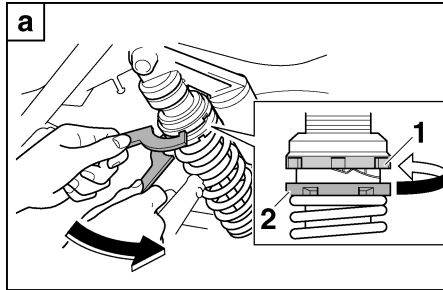

1. Upper ring
2. Lower ring (spring preload adjusting ring)

Adjust the spring preload as follows, using the special wrenches included along with the owner's tool kit.

To increase the spring preload and thereby harden the suspension, hold the upper ring in place while turning the lower ring (adjusting ring) on each shock absorber assembly as shown in illustration [a].

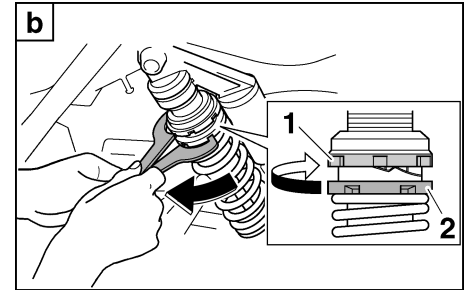

1. Upper ring
2. Lower ring (spring preload adjusting ring)

To decrease the spring preload and thereby soften the suspension, hold the upper ring in place while turning the lower ring (adjusting ring) on each shock absorber assembly as shown in illustration [b].

# INSTRUMENT AND CONTROL FUNCTIONS

EAU00316

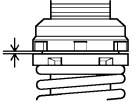
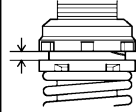
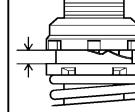
Setting		
Minimum (soft)/ standard	Medium	Maximum (hard)
<b>1</b> 	<b>2</b> 	<b>3</b> 

## **⚠ WARNING**

These shock absorbers contain highly pressurized nitrogen gas. For proper handling read and understand the following information before handling the shock absorbers. The manufacturer cannot be held responsible for property damage or personal injury that may result from improper handling.

- Do not tamper with or attempt to open the gas cylinders.
- Do not subject the shock absorbers to an open flame or other high heat sources, otherwise they may explode due to excessive gas pressure.
- Do not deform or damage the gas cylinders in any way, as this will result in poor damping performance.
- Always have a Yamaha dealer service the shock absorbers.

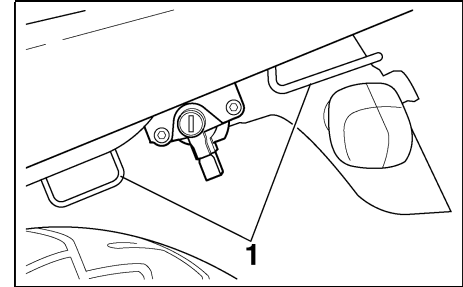

1. Luggage strap holder (× 4)

EAU04276

## Luggage strap holders

There are four luggage strap holders, two of which can be turned out for easier access.

## Sidestand

The sidestand is located on the left side of the frame. Raise the sidestand or lower it with your foot while holding the motorcycle upright.

### NOTE:

The built-in sidestand switch is part of the ignition circuit cut-off system, which cuts the ignition in certain situations. (See further down for an explanation of the ignition circuit cut-off system.)

### WARNING

**The motorcycle must not be ridden with the sidestand down, or if the sidestand cannot be properly moved up (or does not stay up), otherwise the sidestand could contact the ground and distract the operator, resulting in a possible loss of control. Yamaha's ignition circuit cut-off system has been designed to assist the operator in fulfilling the responsibility of raising the sidestand before starting off. Therefore, check this system regularly as described below and have a Yamaha dealer repair it if it does not function properly.**

## Ignition circuit cut-off system

The ignition circuit cut-off system (comprising the sidestand switch, clutch switch and neutral switch) has the following functions.

- It prevents starting when the transmission is in gear and the sidestand is up, but the clutch lever is not pulled.
- It prevents starting when the transmission is in gear and the clutch lever is pulled, but the sidestand is still down.
- It cuts the running engine when the transmission is in gear and the sidestand is moved down.

Periodically check the operation of the ignition circuit cut-off system according to the following procedure.



EW000046

**⚠ WARNING**

- The vehicle must be placed on the centerstand during this inspection.
  - If a malfunction is noted, have a Yamaha dealer check the system before riding.
-

# INSTRUMENT AND CONTROL FUNCTIONS

3

With the engine turned off:  
1. Move the sidestand down.  
2. Make sure that the engine stop switch is set to “O”.  
3. Turn the key to “ON”.  
4. Shift the transmission into the neutral position.  
5. Push the start switch.  
**Does the engine start?**

YES NO

**NOTE:** \_\_\_\_\_  
This check is most reliable if performed with a warmed-up engine.  
\_\_\_\_\_

The neutral switch may be defective.  
**The motorcycle should not be ridden** until checked by a Yamaha dealer.

With the engine still running:  
6. Move the sidestand up.  
7. Keep the clutch lever pulled.  
8. Shift the transmission into gear.  
9. Move the sidestand down.  
**Does the engine stall?**

YES NO

The sidestand switch may be defective.  
**The motorcycle should not be ridden** until checked by a Yamaha dealer.

After the engine has stalled:  
10. Move the sidestand up.  
11. Keep the clutch lever pulled.  
12. Push the start switch.  
**Does the engine start?**

YES NO

The clutch switch may be defective.  
**The motorcycle should not be ridden** until checked by a Yamaha dealer.

The system is OK. **The motorcycle can be ridden.**

Pre-operation check list ..... 4-1

# PRE-OPERATION CHECKS

The condition of a vehicle is the owner's responsibility. Vital components can start to deteriorate quickly and unexpectedly, even if the vehicle remains unused (for example, as a result of exposure to the elements). Any damage, fluid leakage or loss of tire air pressure could have serious consequences. Therefore, it is very important, in addition to a thorough visual inspection, to check the following points before each ride.

## Pre-operation check list

ITEM	CHECKS	PAGE
<b>Fuel</b>	<ul style="list-style-type: none"><li>• Check fuel level in fuel tank.</li><li>• Refuel if necessary.</li><li>• Check fuel line for leakage.</li></ul>	3-9
<b>Engine oil</b>	<ul style="list-style-type: none"><li>• Check oil level in engine.</li><li>• If necessary, add recommended oil to specified level.</li><li>• Check vehicle for oil leakage.</li></ul>	6-7-6-8
<b>Front brake</b>	<ul style="list-style-type: none"><li>• Check operation.</li><li>• If soft or spongy, have Yamaha dealer bleed hydraulic system.</li><li>• Check fluid level in reservoir.</li><li>• If necessary, add recommended brake fluid to specified level.</li><li>• Check hydraulic system for leakage.</li></ul>	6-19-6-20
<b>Rear brake</b>	<ul style="list-style-type: none"><li>• Check operation.</li><li>• If soft or spongy, have Yamaha dealer bleed hydraulic system.</li><li>• Check fluid level in reservoir.</li><li>• If necessary, add recommended brake fluid to specified level.</li><li>• Check hydraulic system for leakage.</li></ul>	6-17-6-20
<b>Clutch</b>	<ul style="list-style-type: none"><li>• Check operation.</li><li>• If soft or spongy, have Yamaha dealer bleed hydraulic system.</li><li>• Check fluid level in reservoir.</li><li>• If necessary, add recommended fluid to specified level.</li><li>• Check hydraulic system for leakage.</li></ul>	6-19-6-20
<b>Throttle grip</b>	<ul style="list-style-type: none"><li>• Make sure that operation is smooth.</li><li>• Check free play.</li><li>• If necessary, have Yamaha dealer make adjustment or lubricate.</li></ul>	6-13
<b>Control cables</b>	<ul style="list-style-type: none"><li>• Make sure that operation is smooth.</li><li>• Lubricate if necessary.</li></ul>	6-23

# PRE-OPERATION CHECKS

ITEM	CHECKS	PAGE
Drive chain	<ul style="list-style-type: none"> <li>• Check chain slack.</li> <li>• Adjust if necessary.</li> <li>• Check chain condition.</li> <li>• Lubricate if necessary.</li> </ul>	6-21,6-23
Wheels and tires	<ul style="list-style-type: none"> <li>• Check for damage.</li> <li>• Check tire condition and tread depth.</li> <li>• Check air pressure.</li> <li>• Correct if necessary.</li> </ul>	6-14-6-17
Brake and shift pedals	<ul style="list-style-type: none"> <li>• Make sure that operation is smooth.</li> <li>• Lubricate pedal pivoting points if necessary.</li> </ul>	6-24
Brake and clutch levers	<ul style="list-style-type: none"> <li>• Make sure that operation is smooth.</li> <li>• Lubricate lever pivoting points if necessary.</li> </ul>	6-24
Centerstand, sidestand	<ul style="list-style-type: none"> <li>• Make sure that operation is smooth.</li> <li>• Lubricate pivots if necessary.</li> </ul>	6-25
Chassis fasteners	<ul style="list-style-type: none"> <li>• Make sure that all nuts, bolts and screws are properly tightened.</li> <li>• Tighten if necessary.</li> </ul>	—
Instruments, lights, signals and switches	<ul style="list-style-type: none"> <li>• Check operation.</li> <li>• Correct if necessary.</li> </ul>	—
Sidestand switch	<ul style="list-style-type: none"> <li>• Check operation of ignition circuit cut-off system.</li> <li>• If system is defective, have Yamaha dealer check vehicle.</li> </ul>	3-16

**NOTE:**

Pre-operation checks should be made each time the motorcycle is used. Such an inspection can be accomplished in a very short time; and the added safety it assures is more than worth the time involved.

EWA00033

**⚠ WARNING**

**If any item in the Pre-operation check list is not working properly, have it inspected and repaired before operating the motorcycle.**



# OPERATION AND IMPORTANT RIDING POINTS

---

Starting a cold engine .....	5-1
Starting a warm engine .....	5-2
Shifting .....	5-3
Recommended shift points (for Switzerland only) .....	5-3
Tips for reducing fuel consumption .....	5-4
Engine break-in .....	5-4
Parking .....	5-5

EAU00373

**⚠ WARNING**

- Become thoroughly familiar with all operating controls and their functions before riding. Consult a Yamaha dealer regarding any control or function that you do not thoroughly understand.
- Never start the engine or operate it in a closed area for any length of time. Exhaust fumes are poisonous, and inhaling them can cause loss of consciousness and death within a short time. Always make sure that there is adequate ventilation.
- Before starting out, make sure that the sidestand is up. If the sidestand is not raised completely, it could contact the ground and distract the operator, resulting in a possible loss of control.

## Starting a cold engine

In order for the ignition circuit cut-off system to enable starting, one of the following conditions must be met:

- The transmission is in the neutral position.
- The transmission is in gear with the clutch lever pulled and the sidestand up.

EAU00381\*

EW000054

**⚠ WARNING**

- Before starting the engine, check the function of the ignition circuit cut-off system according to the procedure described on page 3-19.
- Never ride with the sidestand down.

1. Turn the fuel cock lever to "ON".
2. Turn the key to "ON" and make sure that the engine stop switch is set to "○".
3. Shift the transmission into the neutral position.

**NOTE:**

When the transmission is in the neutral position, the neutral indicator light should be on, otherwise have a Yamaha dealer check the electrical circuit.

4. Turn the starter (choke) on and completely close the throttle. (See page 3-11 for starter (choke) operation.)
5. Start the engine by pushing the start switch.

**NOTE:**

If the engine fails to start, release the start switch, wait a few seconds, and then try again. Each starting attempt should be as short as possible to preserve the battery. Do not crank the engine more than 10 seconds on any one attempt.



---

---

# OPERATION AND IMPORTANT RIDING POINTS

---

---

EC000034

**CAUTION:** \_\_\_\_\_

The oil level warning light should come on when the start switch is pushed, and it should go off when the start switch is released. If the oil level warning light flickers or remains on after starting, immediately stop the engine, and then check the engine oil level and the vehicle for oil leakage. If necessary, add engine oil, and then check the warning light again. If the warning light does not come on when pushing the start switch, or if it does not go off after starting with sufficient engine oil, have a Yamaha dealer check the electrical circuit.

- 
6. After starting the engine, move the starter (choke) lever back halfway.

ECA00045

**CAUTION:** \_\_\_\_\_

For maximum engine life, never accelerate hard when the engine is cold!

---

7. When the engine is warm, turn the starter (choke) off.

**NOTE:** \_\_\_\_\_

The engine is warm when it responds normally to the throttle with the starter (choke) turned off.

---

EAU01258

## Starting a warm engine

Follow the same procedure as for starting a cold engine with the exception that the starter (choke) is not required when the engine is warm.

# OPERATION AND IMPORTANT RIDING POINTS

EC000048

EAU02941

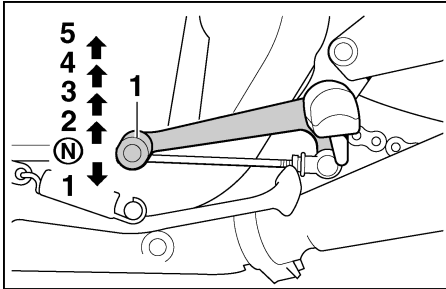

1. Shift pedal  
N. Neutral position

EAU00423

5

## Shifting

Shifting gears lets you control the amount of engine power available for starting off, accelerating, climbing hills, etc.

The gear positions are shown in the illustration.

### NOTE:

To shift the transmission into the neutral position, press the shift pedal down repeatedly until it reaches the end of its travel, and then slightly raise it.

### CAUTION:

- Even with the transmission in the neutral position, do not coast for long periods of time with the engine off, and do not tow the motorcycle for long distances. The transmission is properly lubricated only when the engine is running. Inadequate lubrication may damage the transmission.
- Always use the clutch while changing gears to avoid damaging the engine, transmission, and drive train, which are not designed to withstand the shock of forced shifting.

## Recommended shift points (for Switzerland only)

The recommended shift points during acceleration are shown in the table below.

	Shift point (km/h)
1st → 2nd	23
2nd → 3rd	36
3rd → 4th	50
4th → 5th	60

### NOTE:

When shifting down two gears at a time, reduce the speed accordingly (e.g., down to 35 km/h when shifting from 4th to 2nd gear).

# OPERATION AND IMPORTANT RIDING POINTS

## Tips for reducing fuel consumption

EAU00424

Fuel consumption depends largely on your riding style. Consider the following tips to reduce fuel consumption:

- Thoroughly warm up the engine.
- Turn the starter (choke) off as soon as possible.
- Shift up swiftly, and avoid high engine speeds during acceleration.
- Do not rev the engine while shifting down, and avoid high engine speeds with no load on the engine.
- Turn the engine off instead of letting it idle for an extended length of time (e.g., in traffic jams, at traffic lights or at railroad crossings).

## Engine break-in

EAU01128

There is never a more important period in the life of your engine than the period between 0 and 1,600 km. For this reason, you should read the following material carefully.

Since the engine is brand new, do not put an excessive load on it for the first 1,600 km. The various parts in the engine wear and polish themselves to the correct operating clearances. During this period, prolonged full-throttle operation or any condition that might result in engine overheating must be avoided.

## 0–1,000 km

Avoid prolonged operation above 4,000 r/min.

EAU03749\*

## 1,000–1,600 km

Avoid prolonged operation above 5,000 r/min.

EC000052\*

### CAUTION:

**After 1,000 km of operation, the engine oil must be changed and the oil filter element replaced.**

## 1,600 km and beyond

The vehicle can now be operated normally.

EC000053

### CAUTION:

- Keep the engine speed out of the tachometer red zone.
- If any engine trouble should occur during the engine break-in period, immediately have a Yamaha dealer check the vehicle.

# OPERATION AND IMPORTANT RIDING POINTS

---

---

EAU00460

## Parking

When parking, stop the engine, and then remove the key from the main switch.

EW000058

### **WARNING**

- Since the engine and exhaust system can become very hot, park in a place where pedestrians or children are not likely to touch them.
- Do not park on a slope or on soft ground, otherwise the motorcycle may overturn.

# PERIODIC MAINTENANCE AND MINOR REPAIR

Owner's tool kit .....	6-1	Checking and lubricating the throttle grip and cable .....	6-24
Periodic maintenance and lubrication chart .....	6-2	Checking and lubricating the brake and shift pedals .....	6-24
Removing and installing the panel .....	6-5	Checking and lubricating the brake and clutch levers .....	6-24
Checking the spark plugs .....	6-6	Checking and lubricating the centerstand and sidestand .....	6-25
Engine oil and oil filter element .....	6-7	Checking the front fork .....	6-25
Cleaning the air filter element .....	6-11	Checking the steering .....	6-26
Adjusting the carburetors .....	6-12	Checking the wheel bearings .....	6-27
Adjusting the engine idling speed .....	6-13	Battery .....	6-27
Adjusting the throttle cable free play .....	6-13	Replacing the fuses .....	6-29
Adjusting the valve clearance .....	6-14	Replacing the headlight bulb .....	6-29
Tires .....	6-14	Replacing a tail/brake light bulb .....	6-31
Cast wheels .....	6-17	Replacing a turn signal light bulb .....	6-31
Adjusting the brake pedal position .....	6-17	Front wheel .....	6-32
Rear brake light switch adjustment .....	6-18	Rear wheel .....	6-34
Checking the front and rear brake pads .....	6-19	Troubleshooting .....	6-36
Checking the brake and clutch fluid levels .....	6-19	Troubleshooting chart .....	6-37
Changing the brake and clutch fluids .....	6-21		
Drive chain slack .....	6-21		
Lubricating the drive chain .....	6-23		
Checking and lubricating the cables .....	6-23		

EAU00464

Safety is an obligation of the owner. Periodic inspection, adjustment and lubrication will keep your vehicle in the safest and most efficient condition possible. The most important points of inspection, adjustment, and lubrication are explained on the following pages. The intervals given in the periodic maintenance and lubrication chart should be simply considered as a general guide under normal riding conditions. However, **DEPENDING ON THE WEATHER, TERRAIN, GEOGRAPHICAL LOCATION, AND INDIVIDUAL USE, THE MAINTENANCE INTERVALS MAY NEED TO BE SHORTENED.**

EW000060

**⚠ WARNING**

**If you are not familiar with motorcycle maintenance work, have a Yamaha dealer do it for you.**

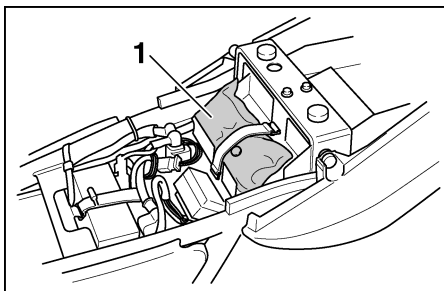

1. Owner's tool kit

EAU03758

## Owner's tool kit

The owner's tool kit is located under the seat. (See page 3-11 for seat removal and installation procedures.) The service information included in this manual and the tools provided in the owner's tool kit are intended to assist you in the performance of preventive maintenance and minor repairs. However, additional tools such as a torque wrench may be necessary to perform certain maintenance work correctly.

**NOTE:**

If you do not have the tools or experience required for a particular job, have a Yamaha dealer perform it for you.

EW000063

**⚠ WARNING**

**Modifications not approved by Yamaha may cause loss of performance and render the vehicle unsafe for use. Consult a Yamaha dealer before attempting any changes.**

# PERIODIC MAINTENANCE AND MINOR REPAIR

EAU03685

## Periodic maintenance and lubrication chart

### NOTE:

- The annual checks must be performed every year, except if a kilometer-based maintenance is performed instead.
- From 50,000 km, repeat the maintenance intervals starting from 10,000 km.
- Items marked with an asterisk should be performed by a Yamaha dealer as they require special tools, data and technical skills.

NO.	ITEM	CHECK OR MAINTENANCE JOB	ODOMETER READING (× 1,000 km)					ANNUAL CHECK
			1	10	20	30	40	
1	* Fuel line	• Check fuel hoses and vacuum hose for cracks or damage.		√	√	√	√	√
2	* Fuel filter	• Check condition.			√		√	
3	Spark plugs	• Check condition. • Clean and regap.		√		√		
		• Replace.			√		√	
4	* Valves	• Check valve clearance. • Adjust.	Every 20,000 km					
5	Air filter element	• Clean.		√		√		
		• Replace.			√		√	
6	* Clutch	• Check operation, fluid level and vehicle for fluid leakage. (See NOTE on page 6-4.)	√	√	√	√	√	
7	* Front brake	• Check operation, fluid level and vehicle for fluid leakage. (See NOTE on page 6-4.)	√	√	√	√	√	√
		• Replace brake pads.	Whenever worn to the limit					
8	* Rear brake	• Check operation, fluid level and vehicle for fluid leakage. (See NOTE on page 6-4.)	√	√	√	√	√	√
		• Replace brake pads.	Whenever worn to the limit					

# PERIODIC MAINTENANCE AND MINOR REPAIR

NO.	ITEM	CHECK OR MAINTENANCE JOB	ODOMETER READING (× 1,000 km)					ANNUAL CHECK
			1	10	20	30	40	
9	* Brake hoses	• Check for cracks or damage.		√	√	√	√	√
		• Replace. (See NOTE on page 6-4.)	Every 4 years					
10	* Wheels	• Check runout and for damage.		√	√	√	√	
11	* Tires	• Check tread depth and for damage. • Replace if necessary. • Check air pressure. • Correct if necessary.		√	√	√	√	√
12	* Wheel bearings	• Check bearing for looseness or damage.		√	√	√	√	
13	* Swingarm	• Check operation and for excessive play.		√	√	√	√	
		• Lubricate with lithium-soap-based grease.	Every 50,000 km					
14	Drive chain	• Check chain slack. • Make sure that the rear wheel is properly aligned. • Clean and lubricate.	Every 1,000 km and after washing the motorcycle or riding in the rain					
15	* Steering bearings	• Check bearing play and steering for roughness.	√	√	√	√	√	
		• Lubricate with lithium-soap-based grease.	Every 20,000 km					
16	* Chassis fasteners	• Make sure that all nuts, bolts and screws are properly tightened.		√	√	√	√	√
17	Sidestand, centerstand	• Check operation. • Lubricate.		√	√	√	√	√
18	* Sidestand switch	• Check operation.	√	√	√	√	√	√
19	* Front fork	• Check operation and for oil leakage.		√	√	√	√	
20	* Shock absorber assemblies	• Check operation and shock absorbers for oil leakage.		√	√	√	√	
21	* Carburetors	• Check starter (choke) operation. • Adjust engine idling speed and synchronization.	√	√	√	√	√	√
22	Engine oil	• Change. • Check oil level and vehicle for oil leakage.	√	√	√	√	√	√



# PERIODIC MAINTENANCE AND MINOR REPAIR

NO.	ITEM	CHECK OR MAINTENANCE JOB	ODOMETER READING (× 1,000 km)					ANNUAL CHECK
			1	10	20	30	40	
23	Engine oil filter element	• Replace.	√		√		√	
24	* Front and rear brake switches	• Check operation.	√	√	√	√	√	√
25	Moving parts and cables	• Lubricate.		√	√	√	√	√
26	* Lights, signals and switches	• Check operation. • Adjust headlight beam.	√	√	√	√	√	√

EAU04408

**NOTE:** \_\_\_\_\_

- The air filter needs more frequent service if you are riding in unusually wet or dusty areas.
- Hydraulic brake and clutch service
  - Regularly check and, if necessary, correct the brake and clutch fluid levels.
  - Every two years replace the internal components of the brake master cylinders and calipers as well as clutch master and release cylinders, and change the brake and clutch fluids.
  - Replace the brake and clutch hoses every four years and if cracked or damaged.

# PERIODIC MAINTENANCE AND MINOR REPAIR

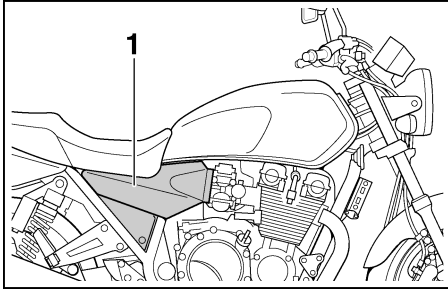

1. Panel A

EAU01777

## Removing and installing the panel

The panel shown above needs to be removed to perform some of the maintenance jobs described in this chapter. Refer to this section each time the panel needs to be removed and installed.

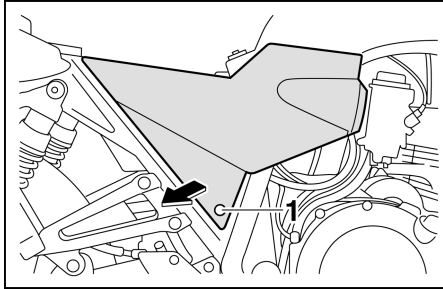

1. Screw

EAU01691

## Panel A

### To remove the panel

1. Remove the seat. (See page 3-11 for seat removal and installation procedures.)
2. Remove the screw, and then take the panel off.

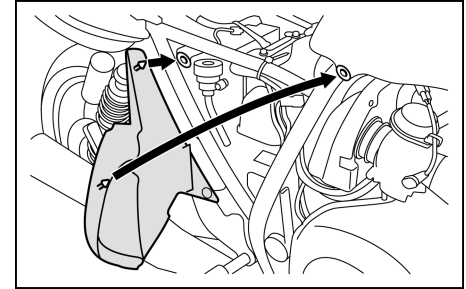

### To install the panel

1. Place the panel in the original position, and then install the screw.
2. Install the seat.

# PERIODIC MAINTENANCE AND MINOR REPAIR

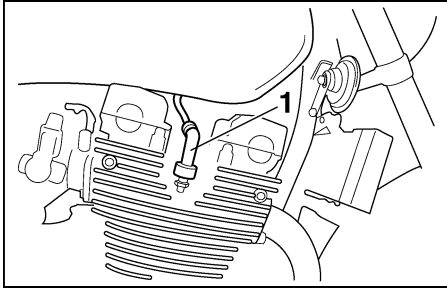

1. Spark plug cap (x 4)

EAU03329

## Checking the spark plugs

The spark plugs are important engine components, which are easy to check. Since heat and deposits will cause any spark plug to slowly erode, the spark plugs should be removed and checked in accordance with the periodic maintenance and lubrication chart. In addition, the condition of the spark plugs can reveal the condition of the engine.

### To remove a spark plug

1. Remove the spark plug cap.

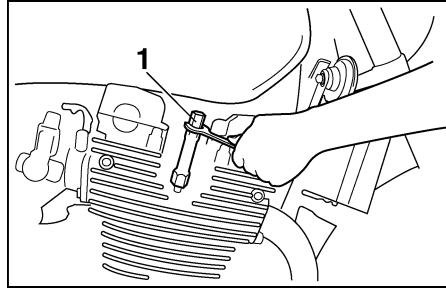

1. Spark plug wrench

2. Remove the spark plug as shown, with the spark plug wrench included in the owner's tool kit.

### To check the spark plugs

1. Check that the porcelain insulator around the center electrode on each spark plug is a medium-to-light tan (the ideal color when the motorcycle is ridden normally).
2. Check that all spark plugs installed in the engine have the same color.

### NOTE:

If any spark plug shows a distinctly different color, the engine could be defective. Do not attempt to diagnose such problems yourself. Instead, have a Yamaha dealer check the motorcycle.

3. Check each spark plug for electrode erosion and excessive carbon or other deposits, and replace it if necessary.

Specified spark plug:  
DPR8EA-9 (NGK) or  
X24EPR-U9 (DENSO)

# PERIODIC MAINTENANCE AND MINOR REPAIR

EAU04409

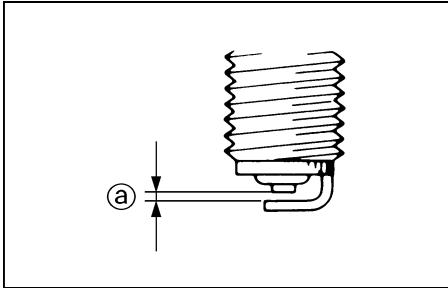

a. Spark plug gap

## To install a spark plug

1. Measure the spark plug gap with a wire thickness gauge and, if necessary, adjust the gap to specification.

Spark plug gap:  
0.8–0.9 mm

2. Clean the surface of the spark plug gasket and its mating surface, and then wipe off any grime from the spark plug threads.

3. Install the spark plug with the spark plug wrench, and then tighten it to the specified torque.

Tightening torque:  
Spark plug:  
17.5 Nm (1.75 m·kgf)

### NOTE:

If a torque wrench is not available when installing a spark plug, a good estimate of the correct torque is 1/4–1/2 turn past finger tight. However, the spark plug should be tightened to the specified torque as soon as possible.

4. Install the spark plug cap.

## Engine oil and oil filter element

The engine oil level should be checked before each ride. In addition, the oil must be changed and the oil filter element replaced at the intervals specified in the periodic maintenance and lubrication chart.

### To check the engine oil level

1. Place the motorcycle on the centerstand.

### NOTE:

Make sure that the motorcycle is positioned straight up when checking the oil level. A slight tilt to the side can result in a false reading.

2. Start the engine, warm it up for several minutes, and then turn it off.

# PERIODIC MAINTENANCE AND MINOR REPAIR

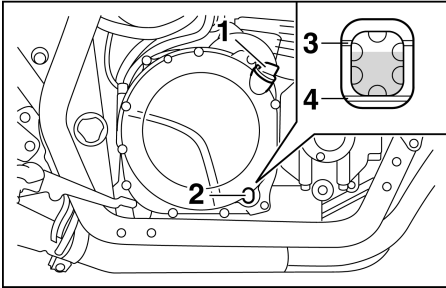

1. Engine oil filler cap
2. Engine oil level check window
3. Maximum level mark
4. Minimum level mark

3. Wait a few minutes until the oil settles, and then check the oil level through the check window located at the bottom-right side of the crankcase.

**NOTE:** \_\_\_\_\_  
The engine oil should be between the minimum and maximum level marks.

4. If the engine oil is below the minimum level mark, add sufficient oil of the recommended type to raise it to the correct level.

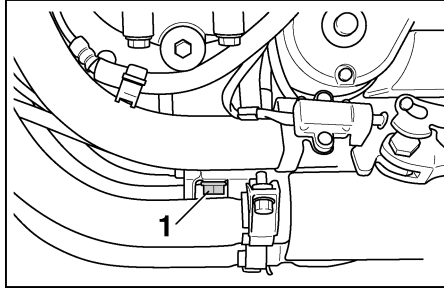

1. Engine oil drain bolt

**To change the engine oil (with or without oil filter element replacement)**

1. Start the engine, warm it up for several minutes, and then turn it off.
2. Place an oil pan under the engine to collect the used oil.
3. Remove the engine oil filler cap and drain bolt to drain the oil from the crankcase.

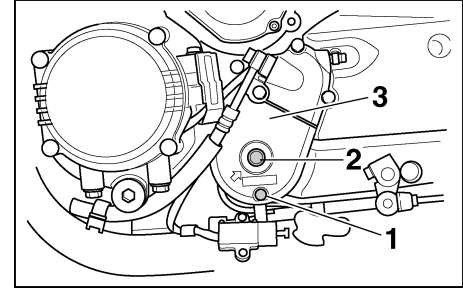

1. Oil filter element drain screw
2. Bolt
3. Oil filter element cover

**NOTE:** \_\_\_\_\_  
Skip steps 4–8 if the oil filter element is not being replaced.

4. Remove the oil filter element drain screw to drain the oil from the oil filter element.
5. Remove the oil filter element cover by removing the bolt.

# PERIODIC MAINTENANCE AND MINOR REPAIR

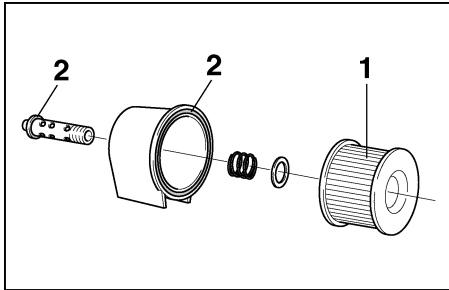

- 1. Oil filter element
- 2. O-ring (× 2)

6. Remove and replace the oil filter element and O-ring.

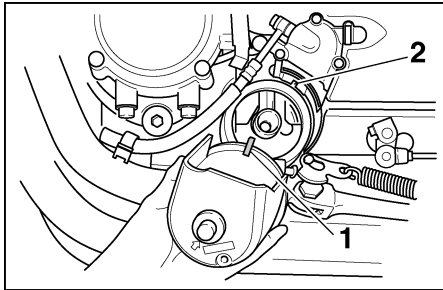

- 1. Projection
- 2. Slot

7. Install the oil filter element cover by aligning the projection on the cover with the slot in the crankcase, installing the bolt, then tightening it to the specified torque.

Tightening torque:  
Oil filter element cover bolt:  
15 Nm (1.5 m·kgf)

**NOTE:** \_\_\_\_\_  
Make sure that the O-ring is properly seated.  
\_\_\_\_\_

8. Install the oil filter element drain screw, and then tighten it to the specified torque.

Tightening torque:  
Oil filter element drain screw:  
7 Nm (0.7 m·kgf)

9. Install the engine oil drain bolt, and then tighten it to the specified torque.

Tightening torque:  
Engine oil drain bolt:  
43 Nm (4.3 m·kgf)

10. Add the specified amount of the recommended engine oil, and then install and tighten the oil filler cap.

# PERIODIC MAINTENANCE AND MINOR REPAIR

Recommended engine oil:

See page 8-1.

Oil quantity:

Without oil filter element  
replacement:

3.0 L

With oil filter element  
replacement:

3.35 L

Total amount (dry engine):

4.2 L

ECA00105

## CAUTION:

- In order to prevent clutch slippage (since the engine oil also lubricates the clutch), do not mix any chemical additives with the oil or use oils of grade “CD” or higher. In addition, do not use oils labeled “ENERGY CONSERVING II” or higher.
- Make sure that no foreign material enters the crankcase.

11. Start the engine, and then let it idle for several minutes while checking it for oil leakage. If oil is leaking, immediately turn the engine off and check for the cause.

## NOTE:

After the engine is started, the engine oil level warning light should go off if the oil level is sufficient.

EC000067

## CAUTION:

**If the oil level warning light flickers or remains on, immediately turn the engine off and have a Yamaha dealer check the vehicle.**

12. Turn the engine off, and then check the oil level and correct it if necessary.

# PERIODIC MAINTENANCE AND MINOR REPAIR

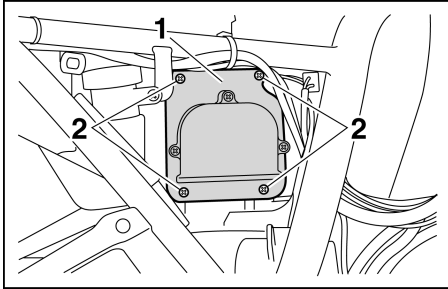

1. Air filter case cover
2. Screw (× 4)

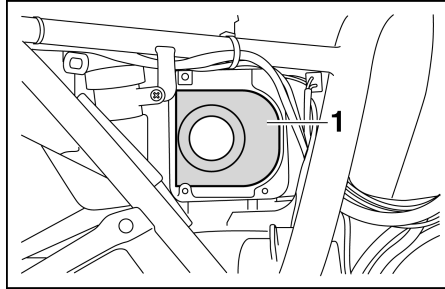

1. Air filter element

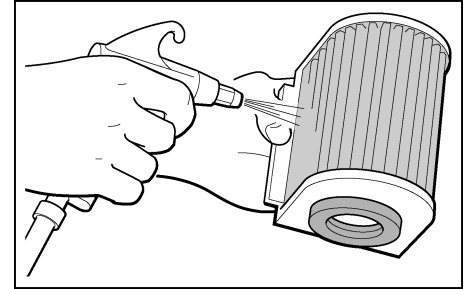

4. Pull the air filter element out.

5. Lightly tap the air filter element to remove most of the dust and dirt, and then blow the remaining dirt out with compressed air as shown. If the air filter element is damaged, replace it.
6. Insert the air filter element into the air filter case.

EAU01070\*

## Cleaning the air filter element

The air filter element should be cleaned at the intervals specified in the periodic maintenance and lubrication chart. Clean the air filter element more frequently if you are riding in unusually wet or dusty areas.

1. Remove the seat. (See page 3-11 for seat removal and installation procedures.)
2. Remove panel A. (See page 6-5 for panel removal and installation procedures.)
3. Remove the air filter case cover by removing the screws.



EC000082\*

**CAUTION:** \_\_\_\_\_

- **Make sure that the air filter element is properly seated in the air filter case.**
- **The engine should never be operated without the air filter element installed, otherwise the pistons and/or cylinders may become excessively worn.**

7. Install the air filter case cover by installing the screws.
8. Install the panel and the seat.

EAU00630

## Adjusting the carburetors

The carburetors are important parts of the engine and require very sophisticated adjustment. Therefore, most carburetor adjustments should be left to a Yamaha dealer, who has the necessary professional knowledge and experience. The adjustment described in the following section, however, may be serviced by the owner as part of routine maintenance.

EC000095

**CAUTION:** \_\_\_\_\_

**The carburetors have been set and extensively tested at the Yamaha factory. Changing these settings without sufficient technical knowledge may result in poor performance of or damage to the engine.**

# PERIODIC MAINTENANCE AND MINOR REPAIR

EAU00632

## Adjusting the engine idling speed

The engine idling speed must be checked and, if necessary, adjusted as follows at the intervals specified in the periodic maintenance and lubrication chart.

1. Start the engine and warm it up for several minutes at 1,000–2,000 r/min while occasionally revving it to 4,000–5,000 r/min.

**NOTE:** \_\_\_\_\_  
The engine is warm when it quickly responds to the throttle.

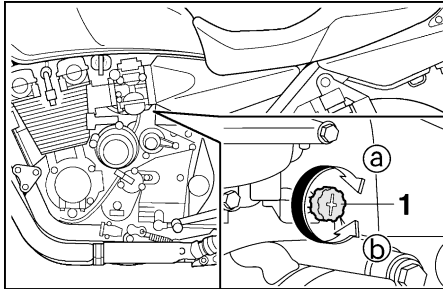

1. Throttle stop screw

2. Check the engine idling speed and, if necessary, adjust it to specification by turning the throttle stop screw. To increase the engine idling speed, turn the screw in direction ①. To decrease the engine idling speed, turn the screw in direction ②.

Engine idling speed:  
950–1,150 r/min

**NOTE:** \_\_\_\_\_  
If the specified idling speed cannot be obtained as described above, have a Yamaha dealer make the adjustment.

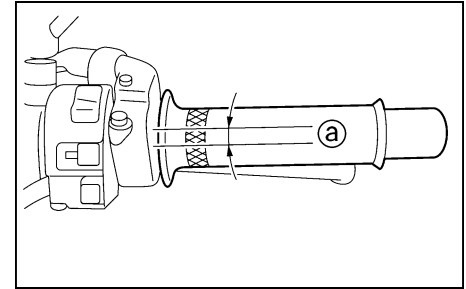

a. Throttle cable free play

EAU00635

## Adjusting the throttle cable free play

The throttle cable free play should measure 3–5 mm at the throttle grip. Periodically check the throttle cable free play and, if necessary, have a Yamaha dealer adjust it.

# PERIODIC MAINTENANCE AND MINOR REPAIR

## Adjusting the valve clearance

EAU00637

The valve clearance changes with use, resulting in improper air-fuel mixture and/or engine noise. To prevent this from occurring, the valve clearance must be adjusted by a Yamaha dealer at the intervals specified in the periodic maintenance and lubrication chart.

## Tires

To maximize the performance, durability, and safe operation of your motorcycle, note the following points regarding the specified tires.

### Tire air pressure

The tire air pressure should be checked and, if necessary, adjusted before each ride.

EAU00658

Tire air pressure (measured on cold tires)		
Load*	Front	Rear
Up to 90 kg	250 kPa (2.50 kgf/cm <sup>2</sup> , 2.50 bar)	250 kPa (2.50 kgf/cm <sup>2</sup> , 2.50 bar)
90 kg–maximum	250 kPa (2.50 kgf/cm <sup>2</sup> , 2.50 bar)	290 kPa (2.90 kgf/cm <sup>2</sup> , 2.90 bar)
High-speed riding	250 kPa (2.50 kgf/cm <sup>2</sup> , 2.50 bar)	290 kPa (2.90 kgf/cm <sup>2</sup> , 2.90 bar)

Maximum load*	203 kg
---------------	--------

\* Total weight of rider, passenger, cargo and accessories

### WARNING

- The tire air pressure must be checked and adjusted on cold tires (i.e., when the temperature of the tires equals the ambient temperature).
- The tire air pressure must be adjusted in accordance with the riding speed and with the total weight of rider, passenger, cargo, and accessories approved for this model.

EW000082

# PERIODIC MAINTENANCE AND MINOR REPAIR

EWA00012

## ⚠ WARNING

Because loading has an enormous impact on the handling, braking, performance and safety characteristics of your motorcycle, you should keep the following precautions in mind.

- **NEVER OVERLOAD THE MOTORCYCLE!** Operation of an overloaded motorcycle may result in tire damage, loss of control, or severe injury. Make sure that the total weight of rider, passenger, cargo, and accessories does not exceed the specified maximum load for the vehicle.
- Do not carry along loosely packed items, which can shift during a ride.
- Securely pack the heaviest items close to the center of the motorcycle and distribute the weight evenly on both sides.

- Adjust the suspension and tire air pressure with regard to the load.
- Check the tire condition and air pressure before each ride.

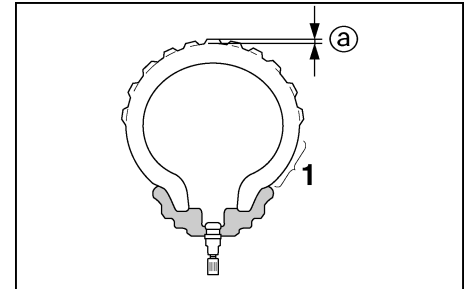

- 1. Tire sidewall
- a. Tire tread depth

## Tire inspection

The tires must be checked before each ride. If the center tread depth reaches the specified limit, if the tire has a nail or glass fragments in it, or if the sidewall is cracked, have a Yamaha dealer replace the tire immediately.

Minimum tire tread depth (front and rear)	1.6 mm
--	--------

## NOTE:

The tire tread depth limits may differ from country to country. Always comply with the local regulations.

# PERIODIC MAINTENANCE AND MINOR REPAIR

EW000079

## ⚠ WARNING

- Have a Yamaha dealer replace excessively worn tires. Besides being illegal, operating the motorcycle with excessively worn tires decreases riding stability and can lead to loss of control.
- The replacement of all wheel- and brake-related parts, including the tires, should be left to a Yamaha dealer, who has the necessary professional knowledge and experience.

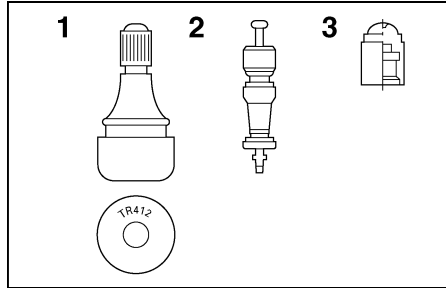

1. Tire air valve
2. Tire air valve core
3. Tire air valve cap with seal

### Tire information

This motorcycle is equipped with cast wheels and tubeless tires with valves.

EW000080

## ⚠ WARNING

- The front and rear tires should be of the same make and design, otherwise the handling characteristics of the motorcycle cannot be guaranteed.
- After extensive tests, only the tires listed below have been approved for this model by Yamaha Motor Co., Ltd.

- Always make sure that the valve caps are securely installed to prevent air pressure leakage.
- Use only the tire valves and valve cores listed below to avoid tire deflation during a high-speed ride.

### FRONT

Manufacturer	Size	Model
Dunlop	120/70 ZR17 (58W)	D220F ST M
	120/70 ZR17 M/C (58W)	
Michelin	120/70 ZR17 (58W)	MACADAM90X E
	120/70 ZR17 M/C (58W)	

### REAR

Manufacturer	Size	Model
Dunlop	180/55 ZR17 (73W)	D220 ST M
	180/55 ZR17 M/C (73W)	
Michelin	180/55 ZR17 (73W)	MACADAM90X E
	180/55 ZR17 M/C (73W)	

### FRONT & REAR

Tire air valve	TR412
Valve core	#9000A (original)

# PERIODIC MAINTENANCE AND MINOR REPAIR

EAU00684

## ⚠ WARNING

This motorcycle is fitted with super-high-speed tires. Note the following points in order to make the most efficient use of these tires.

- Use only the specified replacement tires. Other tires may run the danger of bursting at super high speeds.
- Brand-new tires can have a relatively poor grip on certain road surfaces until they have been “broken in”. Therefore, it is advisable before doing any high-speed riding to ride conservatively for approximately 100 km after installing a new tire.
- The tires must be warmed up before a high-speed run.
- Always adjust the tire air pressure according to the operating conditions.

EAU03773

## Cast wheels

To maximize the performance, durability, and safe operation of your motorcycle, note the following points regarding the specified wheels.

- The wheel rims should be checked for cracks, bends or warpage before each ride. If any damage is found, have a Yamaha dealer replace the wheel. Do not attempt even the smallest repair to the wheel. A deformed or cracked wheel must be replaced.
- The wheel should be balanced whenever either the tire or wheel has been changed or replaced. An unbalanced wheel can result in poor performance, adverse handling characteristics, and a shortened tire life.
- Ride at moderate speeds after changing a tire since the tire surface must first be “broken in” for it to develop its optimal characteristics.

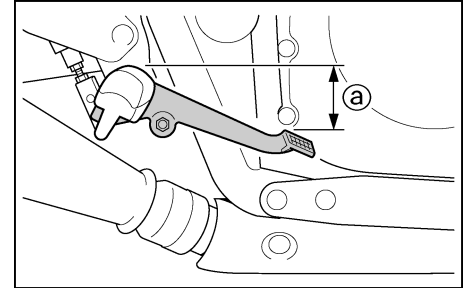

a. Distance between brake pedal and footrest

EAU00712

## Adjusting the brake pedal position

The top of the brake pedal should be positioned approximately 40 mm below the top of the footrest as shown. Periodically check the brake pedal position and, if necessary, have a Yamaha dealer adjust it.

EW000109

EAU01756

## **⚠ WARNING**

A soft or spongy feeling in the brake pedal can indicate the presence of air in the hydraulic system. If there is air in the hydraulic system, have a Yamaha dealer bleed the system before operating the motorcycle. Air in the hydraulic system will diminish the braking performance, which may result in loss of control and an accident.

## Rear brake light switch adjustment

The rear brake light switch, which is activated by the brake pedal, is properly adjusted when the brake light comes on just before braking takes effect. If necessary, adjust the brake light switch as follows.

1. Remove panel A. (See page 6-5 for panel removal and installation procedures.)

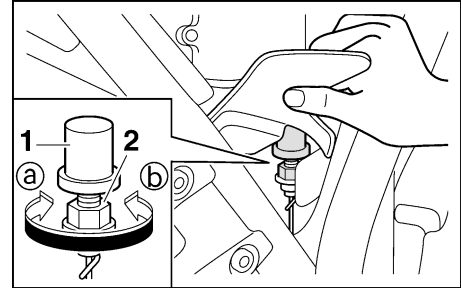

1. Rear brake light switch
  2. Rear brake light switch adjusting nut
2. Turn the adjusting nut while holding the rear brake light switch in place. To make the brake light come on earlier, turn the adjusting nut in direction Ⓐ. To make the brake light come on later, turn the adjusting nut in direction Ⓑ.
  3. Install the panel.

# PERIODIC MAINTENANCE AND MINOR REPAIR

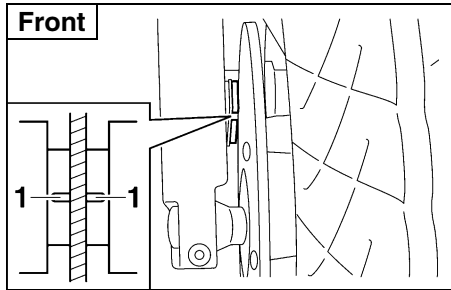

1. Brake pad wear indicator groove

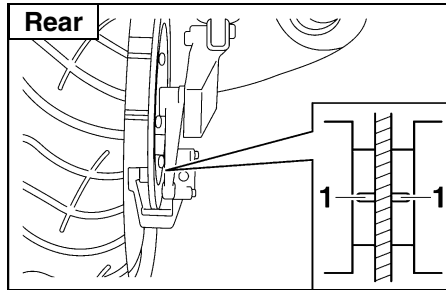

1. Brake pad wear indicator groove

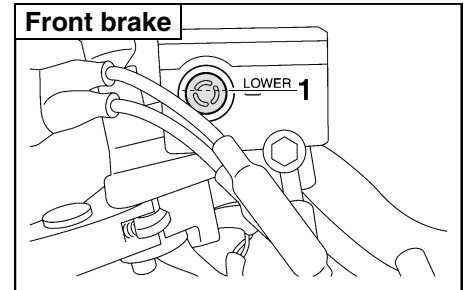

1. Minimum level mark

## Checking the front and rear brake pads

EAU01314

The front and rear brake pads must be checked for wear at the intervals specified in the periodic maintenance and lubrication chart. Each brake pad is provided with a wear indicator groove, which allows you to check the brake pad wear without having to disassemble the brake.

To check the brake pad wear, check the wear indicator grooves. If a brake pad has worn to the point that the wear indicator groove has almost disappeared, have a Yamaha dealer replace the brake pads as a set.

## Checking the brake and clutch fluid levels

EAU04169

Insufficient brake fluid may allow air to enter the brake or clutch systems, possibly causing them to become ineffective.

Before riding, check that the brake fluid is above the minimum level mark and replenish if necessary. A low brake fluid level may indicate worn brake pads and/or brake system leakage. If the brake level is low, be sure to check the brake pads for wear and the brake system for leakage.



# PERIODIC MAINTENANCE AND MINOR REPAIR

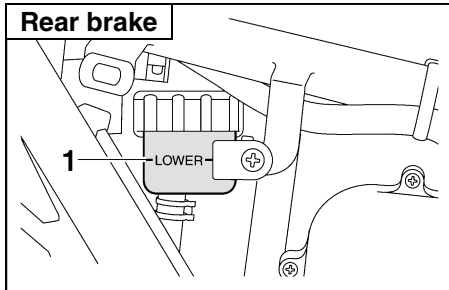

1. Minimum level mark

## NOTE:

The rear brake fluid reservoir is located behind panel A. (See page 6-5 for panel removal and installation procedures.)

Observe these precautions:

- When checking the fluid level, make sure that the top of the brake or clutch fluid reservoir is level.
- Use only the recommended quality brake fluid, otherwise the rubber seals may deteriorate, causing leakage and poor braking or clutch performance.

Recommended brake and clutch fluid: DOT 4 brake fluid

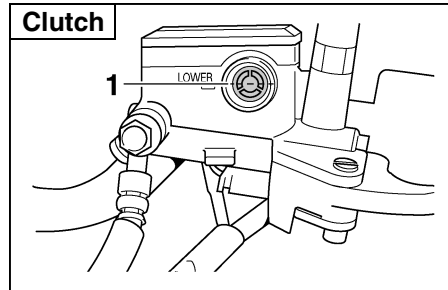

1. Minimum level mark

- Refill with the same type of brake fluid. Mixing fluids may result in a harmful chemical reaction and lead to poor braking or clutch performance.
- The brake or clutch fluid reservoir diaphragm will lose its shape from the negative pressure if the fluid level goes down too far. Be sure to return the diaphragm to its original shape before installing it into the brake or clutch fluid reservoir.

- Be careful that water does not enter the brake or clutch fluid reservoir when refilling. Water will significantly lower the boiling point of the fluid and may result in vapor lock.
- Brake fluid may deteriorate painted surfaces or plastic parts. Always clean up spilled fluid immediately.
- As the brake pads wear, it is normal for the brake fluid level to gradually go down. However, if the brake fluid level goes down suddenly, have a Yamaha dealer check the cause.

# PERIODIC MAINTENANCE AND MINOR REPAIR

EAU03984

## Changing the brake and clutch fluids

Have a Yamaha dealer change the brake and clutch fluids at the intervals specified in the NOTE after the periodic maintenance and lubrication chart. In addition, have the oil seals of the brake and clutch master cylinders and calipers as well as the brake and clutch hoses replaced at the intervals listed below or whenever they are damaged or leaking.

- Oil seals: Replace every two years.
- Brake and clutch hoses: Replace every four years.

EAU00745

## Drive chain slack

The drive chain slack should be checked before each ride and adjusted if necessary.

### To check the drive chain slack

1. Place the motorcycle on the centerstand.

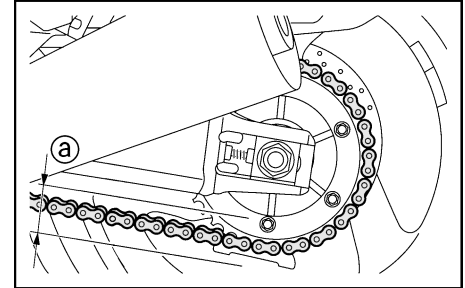

a. Drive chain slack

2. Shift the transmission into the neutral position.
3. Spin the rear wheel several times to locate the tightest portion of the drive chain.
4. Measure the drive chain slack as shown.

Drive chain slack:  
20–30 mm

5. If the drive chain slack is incorrect, adjust it as follows.

# PERIODIC MAINTENANCE AND MINOR REPAIR

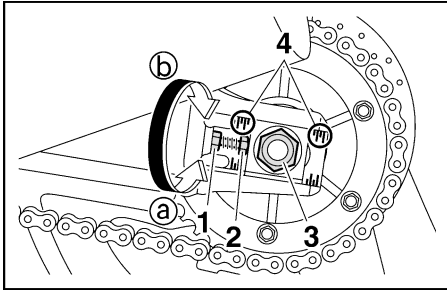

1. Locknut
2. Drive chain slack adjusting bolt
3. Axle nut
4. Alignment marks

EAU03608

## To adjust the drive chain slack

1. Loosen the axle nut and the locknut on each side of the swingarm.
2. To tighten the drive chain, turn the adjusting bolt on each side of the swingarm in direction (a). To loosen the drive chain, turn the adjusting bolt on each side of the swingarm in direction (b), and then push the rear wheel forward.

**NOTE:** \_\_\_\_\_  
Using the alignment marks on each side of the swingarm, make sure that both chain pullers are in the same position for proper wheel alignment.

EC000096

**CAUTION:** \_\_\_\_\_  
**Improper drive chain slack will overload the engine as well as other vital parts of the motorcycle and can lead to chain slippage or breakage. To prevent this from occurring, keep the drive chain slack within the specified limits.**

3. Tighten the locknuts, and then tighten the axle nut to the specified torque.

Tightening torque:

Axle nut:

150 Nm (15.0 m·kgf)

# PERIODIC MAINTENANCE AND MINOR REPAIR

## Lubricating the drive chain

EAU03006

The drive chain must be cleaned and lubricated at the intervals specified in the periodic maintenance and lubrication chart, otherwise it will quickly wear out, especially when riding in dusty or wet areas. Service the drive chain as follows.

EC000097

### CAUTION:

**The drive chain must be lubricated after washing the motorcycle or riding in the rain.**

1. Clean the drive chain with kerosene and a small soft brush.

ECA00053

### CAUTION:

**To prevent damaging the O-rings, do not clean the drive chain with steam cleaners, high-pressure washers or inappropriate solvents.**

2. Wipe the drive chain dry.
3. Thoroughly lubricate the drive chain with a special O-ring chain lubricant.

ECA00052

### CAUTION:

**Do not use engine oil or any other lubricants for the drive chain, as they may contain substances that could damage the O-rings.**

EAU02962

## Checking and lubricating the cables

The operation of all control cables and the condition of the cables should be checked before each ride, and the cables and cable ends should be lubricated if necessary. If a cable is damaged or does not move smoothly, have a Yamaha dealer check or replace it.

Recommended lubricant:  
Engine oil

EW000112

### WARNING

**Damage to the outer sheath may interfere with proper cable operation and will cause the inner cable to rust. Replace a damaged cable as soon as possible to prevent unsafe conditions.**

# PERIODIC MAINTENANCE AND MINOR REPAIR

## Checking and lubricating the throttle grip and cable

EAU04034

The operation of the throttle grip should be checked before each ride. In addition, the cable should be lubricated or replaced at the intervals specified in the periodic maintenance chart.

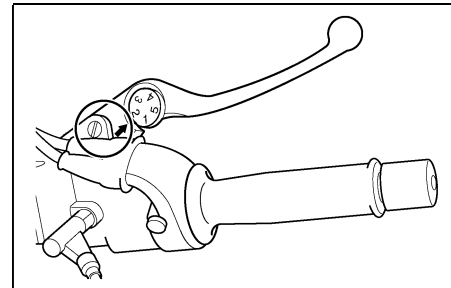
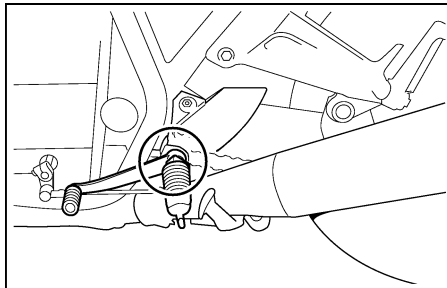

## Checking and lubricating the brake and shift pedals

EAU03370

The operation of the brake and shift pedals should be checked before each ride, and the pedal pivots should be lubricated if necessary.

Recommended lubricant:  
Lithium-soap-based grease  
(all-purpose grease)

## Checking and lubricating the brake and clutch levers

EAU03164

The operation of the brake and clutch levers should be checked before each ride, and the lever pivots should be lubricated if necessary.

Recommended lubricant:  
Lithium-soap-based grease  
(all-purpose grease)

# PERIODIC MAINTENANCE AND MINOR REPAIR

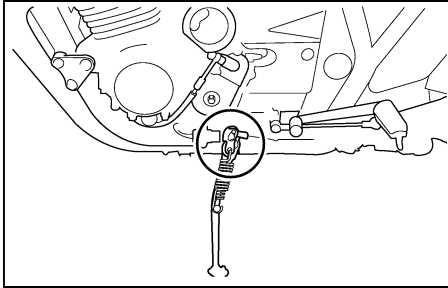

EAU03371

## Checking and lubricating the centerstand and sidestand

The operation of the centerstand and sidestand should be checked before each ride, and the pivots and metal-to-metal contact surfaces should be lubricated if necessary.

EW000114

### **! WARNING**

**If the centerstand or sidestand does not move up and down smoothly, have a Yamaha dealer check or repair it.**

Recommended lubricant:  
Lithium-soap-based grease  
(all-purpose grease)

EAU02939

## Checking the front fork

The condition and operation of the front fork must be checked as follows at the intervals specified in the periodic maintenance and lubrication chart.

### To check the condition

EW000115

### **! WARNING**

**Securely support the motorcycle so that there is no danger of it falling over.**

Check the inner tubes for scratches, damage and excessive oil leakage.

# PERIODIC MAINTENANCE AND MINOR REPAIR

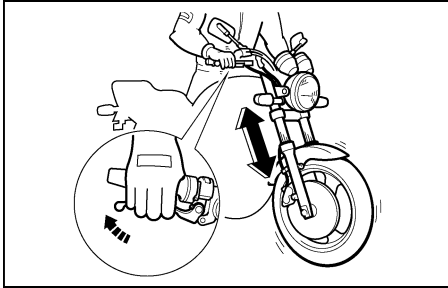

## To check the operation

1. Place the motorcycle on a level surface and hold it in an upright position.
2. While applying the front brake, push down hard on the handlebars several times to check if the front fork compresses and rebounds smoothly.

EC000098

## CAUTION:

**If any damage is found or the front fork does not operate smoothly, have a Yamaha dealer check or repair it.**

## Checking the steering

EAU00794

Worn or loose steering bearings may cause danger. Therefore, the operation of the steering must be checked as follows at the intervals specified in the periodic maintenance and lubrication chart.

1. Place a stand under the engine to raise the front wheel off the ground.

## **! WARNING**

**Securely support the motorcycle so that there is no danger of it falling over.**

EW000115

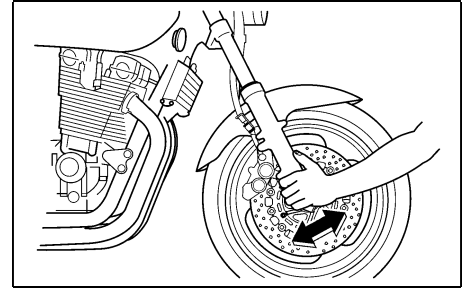

2. Hold the lower ends of the front fork legs and try to move them forward and backward. If any free play can be felt, have a Yamaha dealer check or repair the steering.

# PERIODIC MAINTENANCE AND MINOR REPAIR

---

---

## Checking the wheel bearings

EAU01144

The front and rear wheel bearings must be checked at the intervals specified in the periodic maintenance and lubrication chart. If there is play in the wheel hub or if the wheel does not turn smoothly, have a Yamaha dealer check the wheel bearings.

## Battery

EAU00800

This motorcycle is equipped with a sealed-type (MF) battery, which does not require any maintenance. There is no need to check the electrolyte or to add distilled water.

EC000101

### **CAUTION:**

**Never attempt to remove the battery cell seals, as this would permanently damage the battery.**

---

### **! WARNING**

- **Electrolyte is poisonous and dangerous since it contains sulfuric acid, which causes severe burns. Avoid any contact with skin, eyes or clothing and always shield your eyes when working near batteries. In case of contact, administer the following FIRST AID.**
  - **EXTERNAL:** Flush with plenty of water.
  - **INTERNAL:** Drink large quantities of water or milk and immediately call a physician.
  - **EYES:** Flush with water for 15 minutes and seek prompt medical attention.
- **Batteries produce explosive hydrogen gas. Therefore, keep sparks, flames, cigarettes, etc., away from the battery and provide sufficient ventilation when charging it in an enclosed space.**

EW000116



# PERIODIC MAINTENANCE AND MINOR REPAIR

EC000102

- **KEEP THIS AND ALL BATTERIES OUT OF THE REACH OF CHILDREN.**

## **To charge the battery**

Have a Yamaha dealer charge the battery as soon as possible if it seems to have discharged. Keep in mind that the battery tends to discharge more quickly if the motorcycle is equipped with optional electrical accessories.

## **To store the battery**

1. If the motorcycle will not be used for more than one month, remove the battery, fully charge it, and then place it in a cool, dry place.
2. If the battery will be stored for more than two months, check it at least once a month and fully charge it if necessary.
3. Fully charge the battery before installation.
4. After installation, make sure that the battery leads are properly connected to the battery terminals.

## **CAUTION:**

- Always keep the battery charged. Storing a discharged battery can cause permanent battery damage.
- To charge a sealed-type (MF) battery, a special (constant-voltage) battery charger is required. Using a conventional battery charger will damage the battery. If you do not have access to a sealed-type (MF) battery charger, have a Yamaha dealer charge your battery.

# PERIODIC MAINTENANCE AND MINOR REPAIR

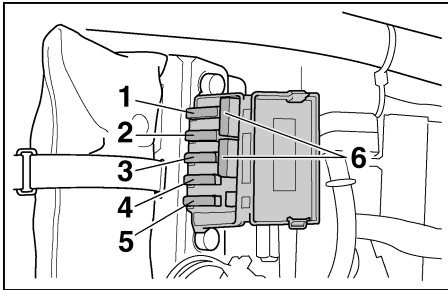

1. Main fuse
2. Signaling system fuse
3. Headlight fuse
4. Ignition fuse
5. Turn signal light fuse
6. Spare fuse (× 2)

EAU04410\*

## Replacing the fuses

The fuse box is located under the seat. (See page 3-11 for seat removal and installation procedures.)

If a fuse is blown, replace it as follows.

1. Turn the key to “OFF” and turn off the electrical circuit in question.
2. Remove the blown fuse, and then install a new fuse of the specified amperage.

### Specified fuses:

Main fuse:	40 A
Ignition fuse:	15 A
Signaling system fuse:	15 A
Headlight fuse:	15 A
Turn signal light fuse:	15 A

EC000103

### CAUTION:

**Do not use a fuse of a higher amperage rating than recommended to avoid causing extensive damage to the electrical system and possibly a fire.**

3. Turn the key to “ON” and turn on the electrical circuit in question to check if the device operates.
4. If the fuse immediately blows again, have a Yamaha dealer check the electrical system.

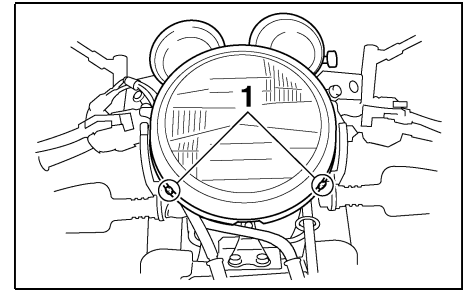

1. Screw (× 2)

EAU04189

## Replacing the headlight bulb

This motorcycle is equipped with a quartz bulb headlight. If the headlight bulb burns out, replace it as follows.

1. Remove the headlight unit by removing the screws.

# PERIODIC MAINTENANCE AND MINOR REPAIR

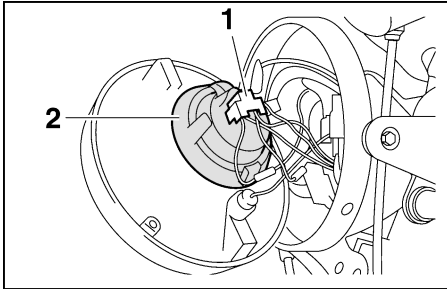

1. Headlight coupler
  2. Bulb cover
2. Disconnect the headlight coupler, and then remove the bulb cover.

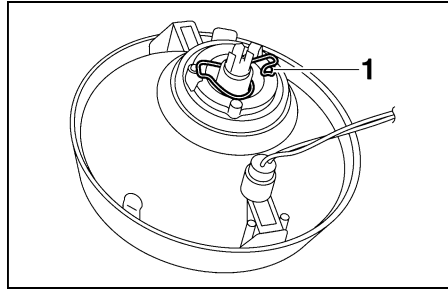

1. Headlight bulb holder
3. Unhook the headlight bulb holder, and then remove the defective bulb.

EW000119

## **⚠ WARNING**

Headlight bulbs get very hot. Therefore, keep flammable products away from a lit headlight bulb, and do not touch the bulb until it has cooled down.

4. Place a new headlight bulb into position, and then secure it with the bulb holder.

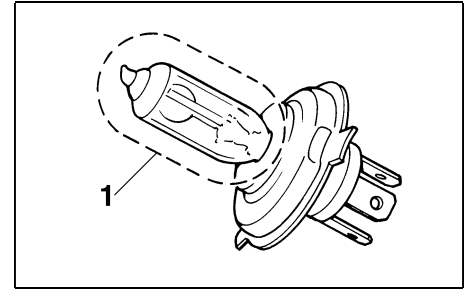

1. Do not touch this area.

EC000105

## **CAUTION:**

Do not touch the glass part of the headlight bulb to keep it free from oil, otherwise the transparency of the glass, the luminosity of the bulb, and the bulb life will be adversely affected. Thoroughly clean off any dirt and fingerprints on the headlight bulb using a cloth moistened with alcohol or thinner.

5. Install the headlight bulb cover, and then connect the coupler.
6. Install the headlight unit by installing the screws.
7. Have a Yamaha dealer adjust the headlight beam if necessary.

# PERIODIC MAINTENANCE AND MINOR REPAIR

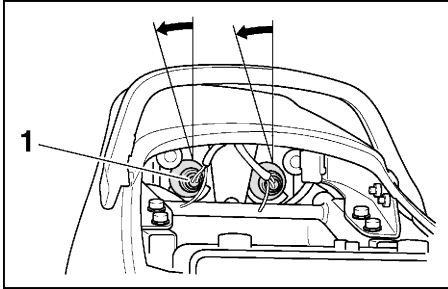

1. Tail/brake light bulb socket

EAU04411

## Replacing a tail/brake light bulb

1. Remove the seat. (See page 3-11 for seat removal and installation procedures.)
2. Remove the socket (together with the bulb) by turning it counterclockwise.
3. Remove the defective bulb by pushing it in and turning it counterclockwise.
4. Insert a new bulb into the socket, push it in, and then turn it clockwise until it stops.
5. Install the socket (together with the bulb) by turning it clockwise.
6. Install the seat.

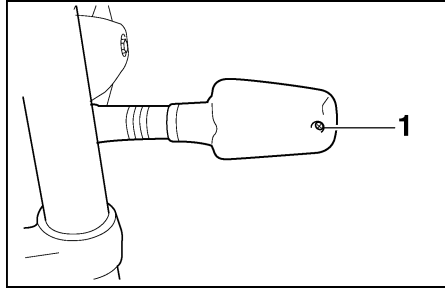

1. Screw

EAU03497

## Replacing a turn signal light bulb

1. Remove the turn signal light lens by removing the screw.

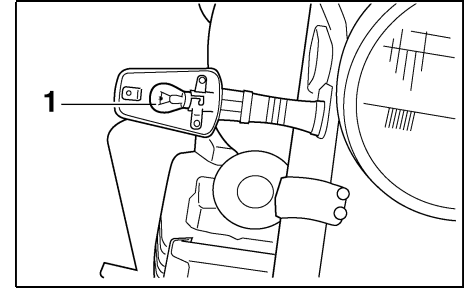

1. Turn signal light bulb

2. Remove the defective bulb by pushing it in and turning it counterclockwise.
3. Insert a new bulb into the socket, push it in, and then turn it clockwise until it stops.
4. Install the lens by installing the screw.

ECA00065

### **CAUTION:**

**Do not overtighten the screw, otherwise the lens may break.**

# PERIODIC MAINTENANCE AND MINOR REPAIR

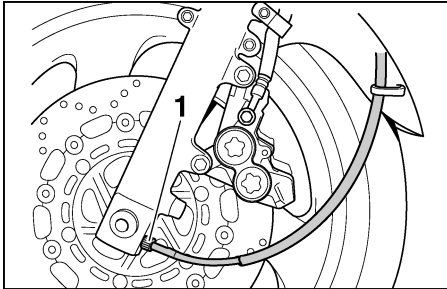

1. Speedometer cable

EAU04412

## Front wheel

### To remove the front wheel

EW000122

#### **WARNING**

- It is advisable to have a Yamaha dealer service the wheel.
- Securely support the motorcycle so that there is no danger of it falling over.

1. Disconnect the speedometer cable from the front wheel.

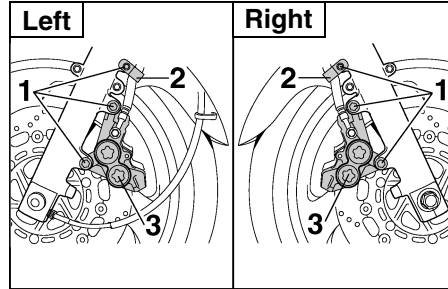

1. Bolt (× 3)
  2. Brake hose holder
  3. Front brake caliper
2. Remove the brake hose holders by removing the bolts.
  3. Remove the brake calipers by removing the bolts.

ECA00047

#### **CAUTION:**

**Do not pull the brake lever after the brake caliper has been removed, otherwise the brake pads will be forced shut.**

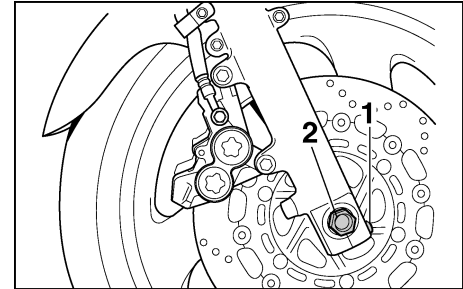

1. Front wheel axle pinch bolt
  2. Wheel axle
4. Loosen the front wheel axle pinch bolt, then the wheel axle.
  5. Place the motorcycle on the centerstand.
  6. Pull the wheel axle out, and then remove the wheel.

# PERIODIC MAINTENANCE AND MINOR REPAIR

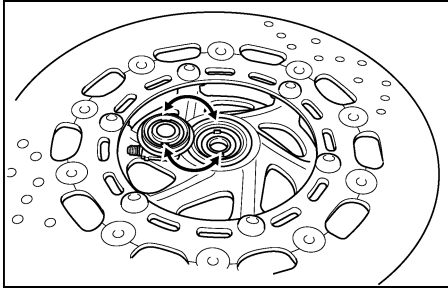

EAU04360

## To install the front wheel

1. Install the speedometer gear unit into the wheel hub so that the projections mesh with the slots.

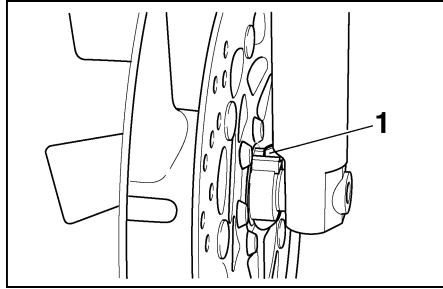

1. Speedometer gear unit retainer

2. Lift the wheel up between the fork legs.

**NOTE:** \_\_\_\_\_  
Make sure that the slot in the speedometer gear unit fits over the retainer on the fork leg.

3. Insert the wheel axle.
4. Install the brake calipers by installing the bolts.

**NOTE:** \_\_\_\_\_  
Make sure that there is enough space between the brake pads before installing the brake calipers onto the brake discs.

5. Install the brake hose holders by installing the bolts.
6. Take the motorcycle off the centerstand so that the front wheel is on the ground.
7. Tighten the wheel axle, then the front wheel axle pinch bolt and the brake caliper bolts to the specified torques.

## Tightening torques:

Wheel axle:

72 Nm (7.2 m·kgf)

Front wheel axle pinch bolt:

20 Nm (2.0 m·kgf)

Brake caliper bolt:

40 Nm (4.0 m·kgf)

8. Connect the speedometer cable.
9. Push down hard on the handlebar several times to check for proper fork operation.

# PERIODIC MAINTENANCE AND MINOR REPAIR

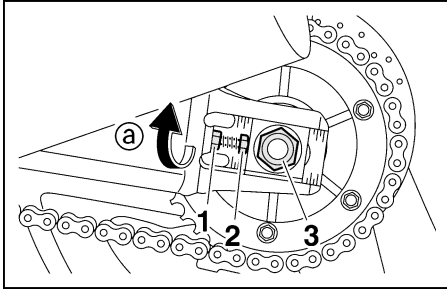

1. Locknut
2. Drive chain slack adjusting bolt
3. Axle nut

EAU04413

## Rear wheel

### To remove the rear wheel

EW000122

#### WARNING

- It is advisable to have a Yamaha dealer service the wheel.
- Securely support the motorcycle so that there is no danger of it falling over.

1. Loosen the axle nut and the brake caliper bolts.

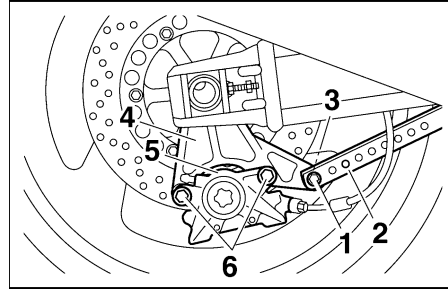

1. Bolt
2. Brake torque rod
3. Nut
4. Brake caliper bracket
5. Brake caliper
6. Bolt (× 2)

2. Disconnect the brake torque rod from the brake caliper bracket by removing the nut and the bolt.
3. Place the motorcycle on the centerstand.

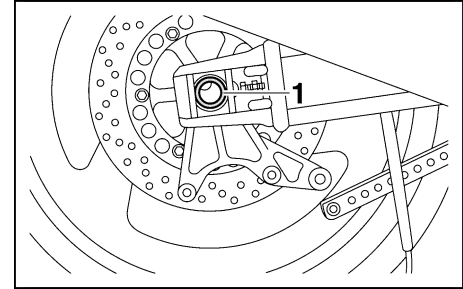

1. Wheel axle

4. Remove the axle nut and the brake caliper by removing the bolts.

ECA00082

#### **CAUTION:**

**Do not apply the brake after the brake caliper has been removed, otherwise the brake pads will be forced shut.**

5. Loosen the locknuts, and then turn the drive chain slack adjusting bolt on each side of the swingarm fully in direction (a).
6. Push the wheel forward, and then remove the drive chain from the rear sprocket.

# PERIODIC MAINTENANCE AND MINOR REPAIR

**NOTE:** \_\_\_\_\_

The drive chain does not need to be disassembled in order to remove and install the rear wheel.

7. While supporting the wheel and the brake caliper bracket, pull the wheel axle out.
8. Remove the brake caliper bracket and the wheel.

EAU03895

**To install the rear wheel**

1. Place the wheel and the brake caliper bracket in the original position.
2. Insert the wheel axle through the brake caliper bracket and wheel from the right-hand side, and then install the axle nut.
3. Install the drive chain onto the rear sprocket, and then adjust the drive chain slack. (See page 6-22 for drive chain slack adjustment procedures.)
4. Connect the brake torque rod to the brake caliper bracket by installing the bolt and the nut.
5. Install the brake caliper by installing the bolts.

**NOTE:** \_\_\_\_\_

Make sure that there is enough space between the brake pads before installing the brake caliper onto the brake disc.

6. Take the motorcycle off the centerstand so that the rear wheel is on the ground.

7. Tighten the axle nut, brake caliper bolts and brake torque rod nut to the specified torques.

Tightening torques:

Axle nut:

150 Nm (15.0 m-kgf)

Brake caliper bolt:

40 Nm (4.0 m-kgf)

Brake torque rod nut:

23 Nm (2.3 m-kgf)



EAU01008

## Troubleshooting

Although Yamaha motorcycles receive a thorough inspection before shipment from the factory, trouble may occur during operation. Any problem in the fuel, compression, or ignition systems, for example, can cause poor starting and loss of power.

The following troubleshooting chart represents a quick and easy procedure for checking these vital systems yourself. However, should your motorcycle require any repair, take it to a Yamaha dealer, whose skilled technicians have the necessary tools, experience, and know-how to service the motorcycle properly.

Use only genuine Yamaha replacement parts. Imitation parts may look like Yamaha parts, but they are often inferior, have a shorter service life and can lead to expensive repair bills.

# PERIODIC MAINTENANCE AND MINOR REPAIR

## Troubleshooting chart

EAU01297

EW000125



**WARNING**

**Keep away from open flames and do not smoke while checking or working on the fuel system.**

### 1. Fuel

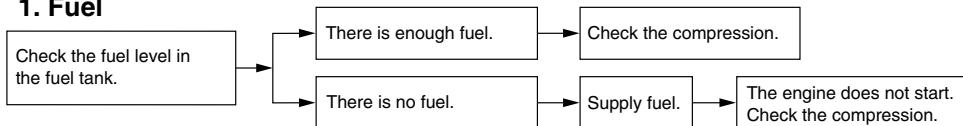

### 2. Compression

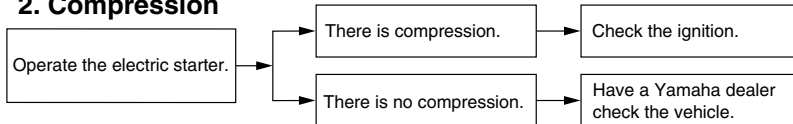

### 3. Ignition

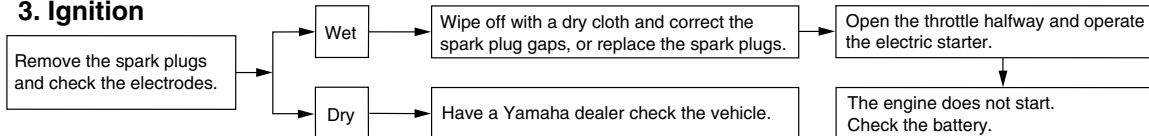

### 4. Battery

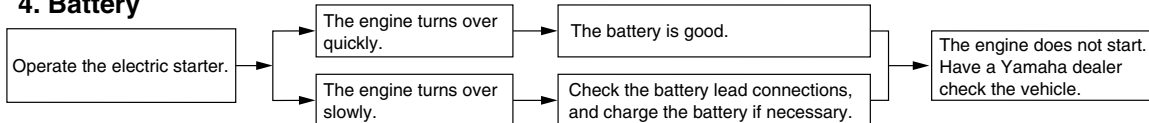

6

# MOTORCYCLE CARE AND STORAGE

---

---

Care .....	7-1
Storage .....	7-4

## Care

While the open design of a motorcycle reveals the attractiveness of the technology, it also makes it more vulnerable. Rust and corrosion can develop even if high-quality components are used. A rusty exhaust pipe may go unnoticed on a car, however, it detracts from the overall appearance of a motorcycle. Frequent and proper care does not only comply with the terms of the warranty, but it will also keep your motorcycle looking good, extend its life and optimize its performance.

## Before cleaning

1. Cover the muffler outlets with plastic bags after the engine has cooled down.
2. Make sure that all caps and covers as well as all electrical couplers and connectors, including the spark plug caps, are tightly installed.
3. Remove extremely stubborn dirt, like oil burnt onto the crankcase, with a degreasing agent and a brush, but never apply such products onto seals, gaskets, sprockets, the drive chain and wheel axles. Always rinse the dirt and degreaser off with water.

## Cleaning

ECA00010

### CAUTION:

- **Avoid using strong acidic wheel cleaners, especially on spoked wheels. If such products are used on hard-to-remove dirt, do not leave the cleaner on the affected area any longer than instructed. Also, thoroughly rinse the area off with water, immediately dry it, and then apply a corrosion protection spray.**
- **Improper cleaning can damage windshields, cowlings, panels and other plastic parts. Use only a soft, clean cloth or sponge with mild detergent and water to clean plastic.**

# MOTORCYCLE CARE AND STORAGE

- Do not use any harsh chemical products on plastic parts. Be sure to avoid using cloths or sponges which have been in contact with strong or abrasive cleaning products, solvent or thinner, fuel (gasoline), rust removers or inhibitors, brake fluid, antifreeze or electrolyte.
- Do not use high-pressure washers or steam-jet cleaners since they cause water seepage and deterioration in the following areas: seals (of wheel and swing-arm bearings, fork and brakes), electric components (couplers, connectors, instruments, switches and lights), breather hoses and vents.
- For motorcycles equipped with a windshield: Do not use strong cleaners or hard sponges as they will cause dulling or scratching. Some cleaning compounds for plastic may leave scratches on the windshield. Test the product on a small hidden part of the windshield to make sure that it does not leave any marks. If the windshield is scratched, use a quality plastic polishing compound after washing.

---

### After normal use

Remove dirt with warm water, a mild detergent, and a soft, clean sponge, and then rinse thoroughly with clean water. Use a toothbrush or bottlebrush for hard-to-reach areas. Stubborn dirt and insects will come off more easily if the area is covered with a wet cloth for a few minutes before cleaning.

### After riding in the rain, near the sea or on salt-sprayed roads

Since sea salt or salt sprayed on roads during winter are extremely corrosive in combination with water, carry out the following steps after each ride in the rain, near the sea or on salt-sprayed roads.

**NOTE:** \_\_\_\_\_  
Salt sprayed on roads in the winter may remain well into spring.

1. Clean the motorcycle with cold water and a mild detergent, after the engine has cooled down.

ECA00012

**CAUTION:** \_\_\_\_\_

**Do not use warm water since it increases the corrosive action of the salt.**

2. After drying the motorcycle, apply a corrosion protection spray on all metal, including chrome- and nickel-plated, surfaces to prevent corrosion.

# MOTORCYCLE CARE AND STORAGE

---

---

## After cleaning

1. Dry the motorcycle with a chamois or an absorbing cloth.
2. Immediately dry the drive chain and lubricate it to prevent it from rusting.
3. Use a chrome polish to shine chrome, aluminum and stainless-steel parts, including the exhaust system. (Even the thermally induced discoloring of stainless-steel exhaust systems can be removed through polishing.)
4. To prevent corrosion, it is recommended to apply a corrosion protection spray on all metal, including chrome- and nickel-plated, surfaces.
5. Use spray oil as a universal cleaner to remove any remaining dirt.
6. Touch up minor paint damage caused by stones, etc.
7. Wax all painted surfaces.
8. Let the motorcycle dry completely before storing or covering it.

EWA00001

### **WARNING**

- **Make sure that there is no oil or wax on the brakes or tires. If necessary, clean the brake discs and brake linings with a regular brake disc cleaner or acetone, and wash the tires with warm water and a mild detergent.**
- **Before operating the motorcycle test its braking performance and cornering behavior.**

ECA00013

### **CAUTION:**

- **Apply spray oil and wax sparingly and make sure to wipe off any excess.**
- **Never apply oil or wax to any rubber and plastic parts, but treat them with a suitable care product.**
- **Avoid using abrasive polishing compounds as they will wear away the paint.**

### **NOTE:**

Consult a Yamaha dealer for advice on what products to use.

# MOTORCYCLE CARE AND STORAGE

## Storage

### Short-term

Always store your motorcycle in a cool, dry place and, if necessary, protect it against dust with a porous cover.

ECA00014

### CAUTION:

- **Storing the motorcycle in a poorly ventilated room or covering it with a tarp, while it is still wet, will allow water and humidity to seep in and cause rust.**
- **To prevent corrosion, avoid damp cellars, stables (because of the presence of ammonia) and areas where strong chemicals are stored.**

### Long-term

Before storing your motorcycle for several months:

1. Follow all the instructions in the “Care” section of this chapter.
2. Turn the fuel cock lever to “ON”.
3. Drain the carburetor float chambers by loosening the drain bolts; this will prevent fuel deposits from building up. Pour the drained fuel into the fuel tank.
4. Fill up the fuel tank and add fuel stabilizer (if available) to prevent the fuel tank from rusting and the fuel from deteriorating.
5. Perform the following steps to protect the cylinders, piston rings, etc. from corrosion.

- a. Remove the spark plug caps and spark plugs.
- b. Pour a teaspoonful of engine oil into each spark plug bore.
- c. Install the spark plug caps onto the spark plugs, and then place the spark plugs on the cylinder head so that the electrodes are grounded. (This will limit sparking during the next step.)
- d. Turn the engine over several times with the starter. (This will coat the cylinder walls with oil.)
- e. Remove the spark plug caps from the spark plugs, and then install the spark plugs and the spark plug caps.

EWA00003

### **WARNING**

**To prevent damage or injury from sparking, make sure to ground the spark plug electrodes while turning the engine over.**

# MOTORCYCLE CARE AND STORAGE

---

---

6. Lubricate all control cables and the pivoting points of all levers and pedals as well as of the sidestand/centerstand.
7. Check and, if necessary, correct the tire air pressure, and then lift the motorcycle so that both of its wheels are off the ground. Alternatively, turn the wheels a little every month in order to prevent the tires from becoming degraded in one spot.
8. Cover the muffler outlets with plastic bags to prevent moisture from entering them.
9. Remove the battery and fully charge it. Store it in a cool, dry place and charge it once a month. Do not store the battery in an excessively cold or warm place (less than 0 °C or more than 30 °C). For more information on storing the battery, see page 6-28.

**NOTE:** \_\_\_\_\_  
Make any necessary repairs before storing the motorcycle.  
\_\_\_\_\_



Specifications ..... 8-1  
Conversion table ..... 8-5

## Specifications

<b>Model</b>	<b>XJR1300</b>
<b>Dimensions</b>	
Overall length	2,175 mm (except for N, S) 2,250 mm (for N, S)
Overall width	775 mm
Overall height	1,115 mm
Seat height	790 mm
Wheelbase	1,510 mm
Ground clearance	120 mm
Minimum turning radius	2,800 mm
<b>Basic weight (with oil and full fuel tank)</b>	<b>247 kg</b>
<b>Engine</b>	
Engine type	Air-cooled 4-stroke, DOHC
Cylinder arrangement	Forward-inclined parallel 4-cylinder
Displacement	1,251 cm <sup>3</sup>
Bore × stroke	79.0 × 63.8 mm
Compression ratio	9.7:1
Starting system	Electric starter
Lubrication system	Wet sump

## Engine oil

### Type

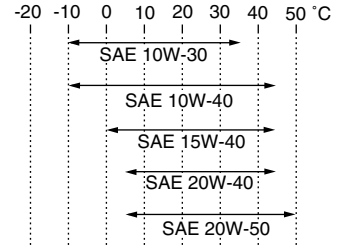

Recommended engine oil classification

API Service SE, SF, SG or higher

### CAUTION:

**Be sure to use motor oils that do not contain anti-friction modifiers. Passenger car motor oils (often labeled "ENERGY CONSERVING II") contain anti-friction additives which will cause clutch and/or starter clutch slippage, resulting in reduced component life and poor engine performance.**

### Quantity

Without oil filter element replacement	3.0 L
With oil filter element replacement	3.35 L
Total amount (dry engine)	4.2 L

# SPECIFICATIONS

<b>Air filter</b>	Dry element
<b>Fuel</b>	
Type	REGULAR UNLEADED GASOLINE ONLY
Fuel tank capacity	21 L
Fuel reserve amount	4.5 L
<b>Carburetor</b>	
Manufacturer	MIKUNI
Model × quantity	BSR37 × 4
<b>Spark plug</b>	
Manufacturer/model	NGK / DPR8EA-9 or DENSO / X24EPR-U9
Gap	0.8–0.9 mm
<b>Clutch type</b>	Wet, multiple-disc
<b>Transmission</b>	
Primary reduction system	Spur gear
Primary reduction ratio	1.750
Secondary reduction system	Chain drive
Secondary reduction ratio	2.167
Number of drive chain sprocket teeth (front/rear)	18/39
Transmission type	Constant-mesh 5-speed
Operation	Left foot

<b>Gear ratio</b>	
1st	2.857
2nd	2.000
3rd	1.571
4th	1.292
5th	1.115

## Chassis

Frame type	Double cradle
Caster angle	25.5 °
Trail	100 mm

## Tires

<b>Front</b>	
Type	Tubeless tire
Size	120/70 ZR17 (58W) 120/70 ZR17 M/C (58W)
Manufacturer/model	Dunlop / D220F ST M Michelin / MACADAM90X E
<b>Rear</b>	
Type	Tubeless tire
Size	180/55 ZR17 (73W) 180/55 ZR17 M/C (73W)
Manufacturer/model	Dunlop / D220 ST M Michelin / MACADAM90X E

# SPECIFICATIONS

Maximum load*	203 kg
Tire air pressure (measured on cold tires)	
Up to 90 kg*	
Front	250 kPa (2.50 kgf/cm <sup>2</sup> , 2.50 bar)
Rear	250 kPa (2.50 kgf/cm <sup>2</sup> , 2.50 bar)
90 kg–maximum*	
Front	250 kPa (2.50 kgf/cm <sup>2</sup> , 2.50 bar)
Rear	290 kPa (2.90 kgf/cm <sup>2</sup> , 2.90 bar)
High-speed riding	
Front	250 kPa (2.50 kgf/cm <sup>2</sup> , 2.50 bar)
Rear	290 kPa (2.90 kgf/cm <sup>2</sup> , 2.90 bar)

\* Total weight of rider, passenger, cargo and accessories

## Wheels

Front	
Type	Cast wheel
Size	17 × MT 3.50
	17 M/C × MT 3.50
Rear	
Type	Cast wheel
Size	17 × MT 5.50
	17 M/C × MT 5.50

## Brakes

Front		
	Type	Dual disc brake
	Operation	Right hand
	Fluid	DOT 4
Rear		
	Type	Single disc brake
	Operation	Right foot
	Fluid	DOT 4

## Suspension

Front	Telescopic fork
Rear	Swingarm

## Springs/shock absorbers

Front	Coil spring / oil damper
Rear	Coil spring / gas-oil damper

## Wheel travel

Front	130 mm
Rear	110 mm

## Electrical system

Ignition system	T.C.I. (digital)
Charging system	
Type	A.C. generator
Standard output	13.5 V, 28 A @ 5,000 r/min

<b>Battery</b>	
Model	GT14B-4
Voltage, capacity	12 V, 12 Ah
<b>Headlight type</b>	Quartz bulb (halogen)
<b>Bulb voltage, wattage × quantity</b>	
Headlight	12 V, 60/55 W × 1
Tail/brake light	12 V, 5/21 W × 2
Auxiliary light	12 V, 4 W × 1
Turn signal light	12 V, 21 W × 4
Meter lighting	12 V, 1.7 W × 4
Neutral indicator light	12 V, 1.7 W × 1
High beam indicator light	12 V, 3.4 W × 1
Oil level warning light	12 V, 1.7 W × 1
Turn signal indicator light	12 V, 1.7 W × 2
<b>Fuses</b>	
Main fuse	40 A
Headlight fuse	15 A
Signaling system fuse	15 A
Ignition fuse	15 A
Turn signal light fuse	15 A

# SPECIFICATIONS

EAU03941

## Conversion table

All specification data in this manual are listed in SI and METRIC UNITS.

Use this table to convert METRIC unit values to IMPERIAL unit values.

Example:

METRIC VALUE	CONVERSION FACTOR		IMPERIAL VALUE
2 mm	× 0.03937	=	0.08 in

## Conversion table

METRIC SYSTEM TO IMPERIAL SYSTEM			
	Metric unit	Conversion factor	Imperial unit
Torque	m-kgf	× 7.233	ft-lb
	m-kgf	× 86.794	in-lb
	cm-kgf	× 0.0723	ft-lb
	cm-kgf	× 0.8679	in-lb
Weight	kg	× 2.205	lb
	g	× 0.03527	oz
Speed	km/h	× 0.6214	mi/h
Distance	km	× 0.6214	mi
	m	× 3.281	ft
	m	× 1.094	yd
	cm	× 0.3937	in
	mm	× 0.03937	in
Volume, Capacity	cc (cm <sup>3</sup> )	× 0.03527	oz (IMP liq.)
	cc (cm <sup>3</sup> )	× 0.06102	cu-in
	L (liter)	× 0.8799	qt (IMP liq.)
	L (liter)	× 0.2199	gal (IMP liq.)
Miscellaneous	kg/mm	× 55.997	lb/in
	kgf/cm <sup>2</sup>	× 14.2234	psi (lb/in <sup>2</sup> )
	°C	× 1.8 + 32	°F

Identification numbers .....	9-1
Key identification number .....	9-1
Vehicle identification number .....	9-1
Model label .....	9-2

## Identification numbers

EAU02944

Record the key identification number, vehicle identification number and model label information in the spaces provided below for assistance when ordering spare parts from a Yamaha dealer or for reference in case the vehicle is stolen.

### 1. KEY IDENTIFICATION NUMBER:

### 2. VEHICLE IDENTIFICATION NUMBER:

### 3. MODEL LABEL INFORMATION:

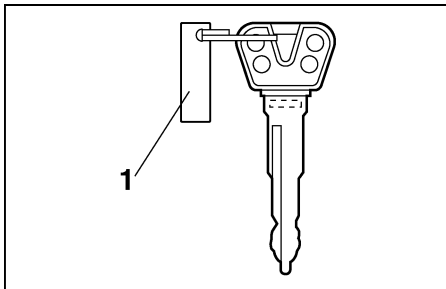

1. Key identification number

EAU01041

## Key identification number

The key identification number is stamped into the key tag. Record this number in the space provided and use it for reference when ordering a new key.

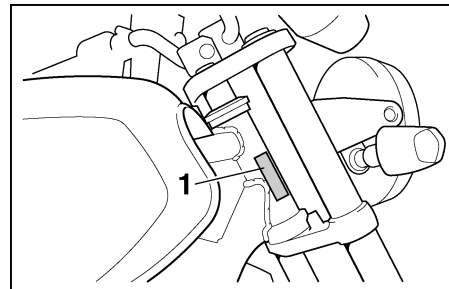

1. Vehicle identification number

EAU01043

## Vehicle identification number

The vehicle identification number is stamped into the steering head pipe. Record this number in the space provided.

### NOTE:

The vehicle identification number is used to identify your motorcycle and may be used to register your motorcycle with the licensing authority in your area.



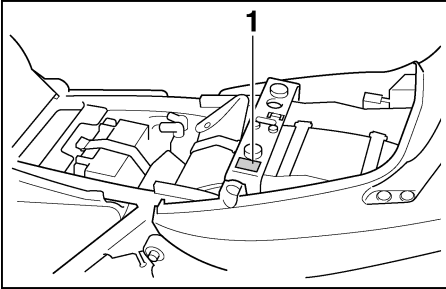

1. Model label

EAU01050

## Model label

The model label is affixed to the frame under the seat. (See page 3-11 for seat removal and installation procedures.) Record the information on this label in the space provided. This information will be needed when ordering spare parts from a Yamaha dealer.

# INDEX

## A

- Air filter element, cleaning .....6-11
- Anti-theft alarm .....3-4

## B

- Battery .....6-27
- Brake and clutch fluid levels, checking ...6-19
- Brake and clutch fluids, changing.....6-21
- Brake and clutch levers, checking and lubricating .....6-24
- Brake and shift pedals, checking and lubricating .....6-24
- Brake lever.....3-7
- Brake light switch (rear), adjusting .....6-18
- Brake pads, checking.....6-19
- Brake pedal.....3-7
- Brake pedal position, adjusting .....6-17

## C

- Cables, checking and lubricating.....6-23
- Carburetors, adjusting.....6-12
- Care.....7-1
- Centerstand and sidestand, checking and lubricating .....6-25
- Clutch lever.....3-5
- Conversion table.....8-5

## D

- Dimmer switch .....3-4
- Drive chain, lubricating.....6-23
- Drive chain slack.....6-21
  - Adjusting .....6-22
  - Checking .....6-21

## E

- Engine break-in .....5-4
- Engine oil and oil filter element.....6-7
- Engine stop switch.....3-5

## F

- Front fork, adjusting .....3-13
- Front fork, checking .....6-25
- Fuel .....3-9
- Fuel cock.....3-10
- Fuel consumption, tips for reducing .....5-4
- Fuel gauge .....3-3
- Fuel tank breather hose.....3-10
- Fuel tank cap.....3-8
- Fuses, replacing .....6-29

## H

- Handlebar switches .....3-4
- Hazard switch.....3-4
- Headlight bulb, replacing .....6-29
- Helmet holder .....3-12
- High beam indicator light .....3-2
- Horn switch .....3-4

## I

- Identification numbers .....9-1
- Idling speed, adjusting.....6-13
- Ignition circuit cut-off system.....3-17
- Indicator and warning lights .....3-2

## K

- Key identification number .....9-1

## L

- Light switch .....3-5
- Luggage strap holders .....3-16

## M

- Main switch/steering lock .....3-1
- Model label .....9-2

## N

- Neutral indicator light .....3-2

## O

- Oil level warning light .....3-2

## P

- Panel, removing and installing.....6-5
- Parking.....5-5
- Part locations .....2-1
- Pass switch.....3-4
- Periodic maintenance and lubrication chart .....6-2
- Pre-operation check list.....4-1

## S

- Safety information .....1-1
- Seat .....3-11
- Shifting.....5-3
- Shift pedal.....3-6
- Shift points (for Switzerland only) .....5-3
- Shock absorber assemblies, adjusting .....3-15
- Sidestand.....3-17
- Spark plugs, checking .....6-6
- Specifications.....8-1
- Speedometer unit.....3-3

Starter (choke) lever .....	3-11
Starting a cold engine .....	5-1
Starting a warm engine.....	5-2
Start switch.....	3-5
Steering, checking.....	6-26
Storage.....	7-4
Storage compartment .....	3-13

## T

Tachometer .....	3-3
Tail/brake light bulb, replacing .....	6-31
Throttle cable free play, adjusting .....	6-13
Throttle grip and cable, checking and lubricating.....	6-24
Tires .....	6-14
Tool kit.....	6-1
Troubleshooting.....	6-36
Troubleshooting chart .....	6-37
Turn signal indicator lights .....	3-2
Turn signal light bulb, replacing .....	6-31
Turn signal switch.....	3-4

## V

Valve clearance, adjusting.....	6-14
Vehicle identification number .....	9-1

## W

Wheel bearings, checking.....	6-27
Wheel (front).....	6-32
Installing.....	6-33
Removing .....	6-32
Wheel (rear) .....	6-34
Installing.....	6-35
Removing.....	6-34

Wheels.....	6-17
-------------	------







PRINTED ON RECYCLED PAPER

PRINTED IN JAPAN  
2001 . 8 - 0.3 × 1 CR  
(E)